

The new equipment generation:
Install, connect and save energy!



Technology for life.

KG-Kompakt
Air handling unit with heat recovery



Application

KG-Kompakt units with heat recovery are designed for controlled ventilation in modern buildings. Due to the regulations relating to energy conservation and air hygiene in buildings, the technical and hygienic requirements for the ventilation systems have also been raised. KG-Kompakt units with heat recovery supply filtered supply air to the different rooms in sufficient and controllable volume. At the same time, a corresponding volume of spent air with increased levels of CO₂ is extracted from the rooms and expelled for disposal from the building.

To reduce energy losses to a minimum, a large proportion of the heat in the exhaust air is recovered and fed via the integrated heat recovery system to the cold fresh air as a form of pre-heating.

This reduces the primary energy costs of the heating system. This high energy efficiency is reflected by the excellent SFP value (specific fan power) of the units.

Description

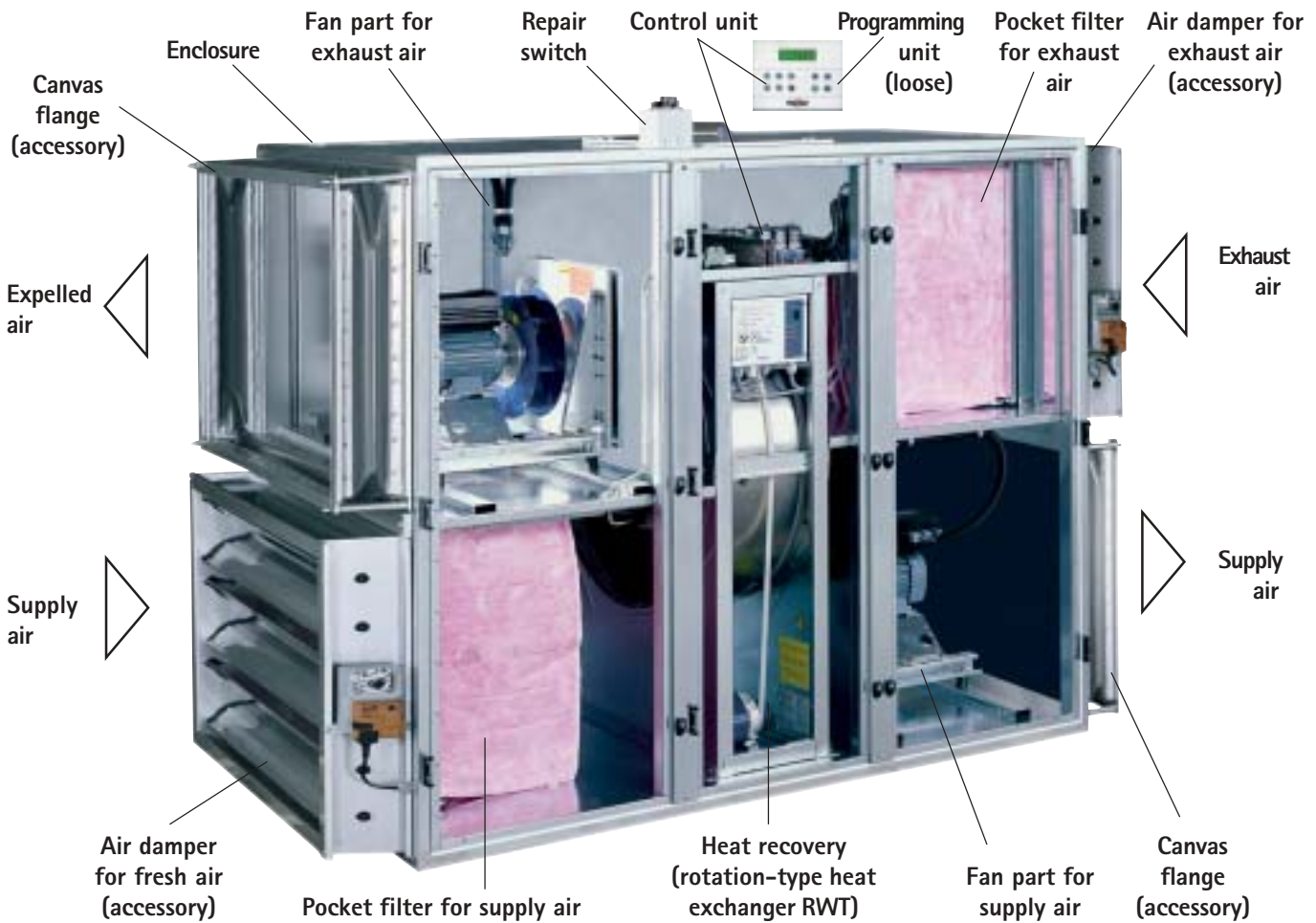

- Combined supply and exhaust air units in a compact design with integrated heat recovery as a rotating storage mass or, depending on size, alternatively with a high-performance countercurrent heat exchanger or crossflow heat exchanger made of corrosion-resistant aluminium alloy.
- Compact unit dimensions (see "Equipment range" table) handling up to 10000 m³/h with external pressure available at up to 500 Pa.
- Unit supplied fully wired and ready for connection for quick and easy commissioning.
- Main isolator offers ultimate safety during maintenance work and repairs.
- Control panel for control and regulating elements.
- The programming unit is loose, which allows it to be used as a remote control as well.
- You can freely assign the supply and waste ducting thanks to the speed setting options on the integrated inverter (swap the supply and exhaust air filters if required).
- Downstream connection of heat exchangers for heating or cooling are available on request (layout designed separately for each order).

Enclosure



Completely smooth internal surfaces

- Compact and inherently stable profile frame construction with a special copper/aluminium weld seam for complete galvanization of the frame construction and durable anti-corrosion protection of the enclosure.
- The structure of the cover panels is a sandwich layout comprising two layers of sheet steel (zinc-plated on both sides) with a layer of insulation in between.
- Optimum noise and heat insulation provided by 50 mm mineral wool, material classification A1, non-combustible in accordance with DIN 4102.
- The KG-Kompakt unit with heat recovery has completely smooth internal surfaces with a gapless floor for perfect cleaning. It thus satisfies the highest requirements in terms of hygienic air handling unit design.
- Full-length inspection doors at operating height along the unit offer easy access to all parts and components.

Motor/fan unit for supply air and exhaust air



Freewheeling fan, inverter mounted directly on the motor enclosure

- Freewheeling fan impeller with unilateral suction and rearward-curved impeller vanes, mounted directly on the motor shaft for lowest **SFP values** and maximum energy efficiency.
- Complete unit mounted on a sturdy base frame equipped with elastic anti-vibration mounts.
- Statically and dynamically balanced impeller.
- High fan efficiency across the full speed range even under low pressure and high volumetric flow rates.
- Dynamic pressure components are mostly converted to usable pressure by the surrounding ring diffuser.
- In conjunction with the inverter, the required air volume can be accurately matched to the system curve.
- Highest EMC class thanks to the direct mounting of the inverter on the motor housing; as a result no interfering electromagnetic radiation can arise on the outside of the unit.
- Motors suitable for 400 V three-phase AC current as standard, thermal motor protection for the motor is provided by a PTC resistor as standard.
- Cost-effective and energy saving operation thanks to very low electrical power consumption.
- Very low maintenance requirements.

Filter



- Supply air filter: pocket filter, class F7.
- Exhaust air filter: pocket filter, class F5 (F7 available on request).
- Supplied as standard with integral filter monitor for supply and exhaust air.

Heat recovery

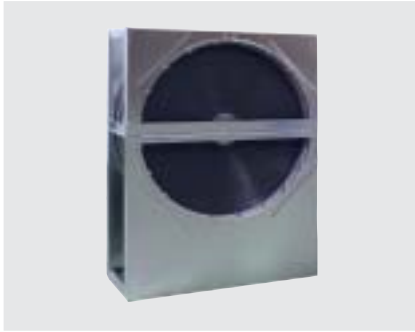

KG-Kompakt 1500, 2500, 4000, 6000, 8000, 10000:

- Integral rotation-type (RWT) heat exchanger with optimized impeller geometry for highest recovery rates of up to 85%.
- Infinitely variable speed control allows the rotor speed to be adapted to all heat recovery requirements.

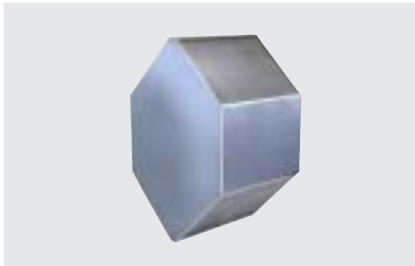

KG-Kompakt 1500 and 2500:

- Heat is recovered via a high-performance PWT countercurrent heat exchanger made of corrosion-proof aluminium for highest heat recovery indices of up to 85%; equipped as standard with a motorised (24 V) airtight bypass damper in accordance with DIN EN 1751, class 2.



KG-Kompakt 4000:

- Heat is recovered via a KGXD crossflow heat exchanger made of corrosion-proof aluminium for heat recovery rates of up to 65%; equipped as standard with a motorised (24 V) airtight bypass damper in accordance with DIN EN 1751, class 2.

Controller



Temperature control (variable speed)

The temperature control is activated via the control of the heat recovery (WRG) system (speed of rotation, damper position), or if required via the mixing valves of following heat exchangers.

The speed may be individually selected by the client on the programming unit GC of the Wolf control system. The control functions causing a modification of the speed may be activated (rapid ventilation, outside temperature controlled speed reduction, speed reduction in combination with minimum supply air limitation, separate speeds for support modes as well as the distinction between day and night speeds).

Volumetric flow control / Pressure regulation

The speed is adapted automatically to the changing pressure conditions of the duct work system by the inverter via the differential pressure sensor. Due to this the pressure of the system remains constant.

The temperature control is activated via the control of the heat recovery (WRG) system (speed of rotation, damper position), or if required via the mixing valves of following heat exchangers.

Factory fitted and wired with various control and safety functions. The programming unit is loose, which allows it to be used as a remote control as well.

Function	Description	
Languages	Menu-guided language selection.	•
LON-Gateway (from Dec. 2005 on)	A gateway module provides the possibility to read out operation data via LON-network	o
eBus-system	The eBus-system makes a combination with other Wolf-products possible without problems	•
Wireless outside sensor	For a wireless transfer of the outside temperature	o
Fault log	Faults logged with info. about quantity of identical faults with time and date of latest identical fault; help for service (fault analysis)	•
Pump anti-seizing function	In order to prevent seizure of the pumps, once a week (the time can be adjusted) the system triggers a protection cycle (service function)	•
Mixer idle function	In order to prevent seizure of the mixers, once a week (the time can be adjusted) the system triggers a protection cycle (service function)	•
Number of controllable temperature zones	Up to 8 independent temperature zones can be controlled via a single programming unit	•
Switching times per day	8 ON und 8 OFF times can be adjusted	•
External connections via plugs	Comfortable installation, connect external cables to plugs and simply plug in	•
Variable motor speed control	With temperature control manually via the programming unit GC With pressure and volumetric flow control automatically via differential pressure sensors	•
Actuation of a heating / cooling circuit pump	Supply of a heating / cooling coil	•
Balance between supply and exhaust air (LCP-2)	Different speeds may be adjusted independently for supply and exhaust air	•
Frost protection function (Anti-frost thermostat)	If the anti-frost thermostat is triggered, the fan is switched off and the coil is flushed	•
Fault message via SMS or eMail (ISDN-module)	In case of a fault an SMS or an eMail (internet connection) is sent via an ISDN-module	o
Radio clock (radio clock module)	For automatic time signal transfer to the eBus, compatible with all Wolf eBus products	o
Easy operation via external programming unit	Programming unit with plain text display, optional use as remote control possible through easy assembly; connections for Bus on the programming unit.	•

- Standard / o accessory

Function	Description	
Pre-heating program	At low outside temperatures (the threshold can be adjusted) the heating circuit is warmed up first to ensure that, if there is a risk of frost, the heater bank is not damaged and no cold air is blown into the system.	•
Support heating/support cooling mode	Maintenance of min. and max. temperature limits in the room while the system is in OFF mode (i.e. during unoccupied periods).	•
Rapid heating	The room is heated to an adjustable set temperature for a limited time.	•
Night ventilation/cooling function	During the night, the building can be cooled down with the cooler fresh air to an adjustable target temperature (unoccupied periods).	•
Burner demand via eBUS	Heat demand to Wolf boilers are sent via eBUS without a zero volt contact.	•
Summer compensation	The set room temperature is gradually changed to follow rising outside temperatures.	•
Eco-Cooling Supply-controlled cooling	If there is a demand for room cooling and a supply of cool fresh air is available, then this supply is used first for cooling. Once the supply is no longer sufficient, the cooling register is actuated.	•
Fault log (100 messages)	Faults logged with info. about the device no., zone no. and date and time of fault .	•
Filter monitoring (via differential pressure switches)	once a week (adjustable time, service function)	•
Connection of a fire alarm	The system is switched off if a fire alarm device is triggered.	•
Thermal motor protection	Monitoring of the motor with a PTC resistor via the inverter.	•
Actuation of the fresh/expelled air damper	230 V OPEN/CLOSE actuation from the circuit board.	•
Outside temperature sensor (mandatory requirement)	Outside temperature sensor for direct connection. Outside temperature sensor for connection to the eBUS. Wireless outside temp. sensor for wireless temp. transmission to the control unit.	0 0 0
Supply air temperature control	The supply air temperature is regulated according to the selected temperature. The sensor probe is loose for assembly in the supply air duct.	•
Supply air/room air control (room sens.)	Room temperature control via room sensors.	0
Supply/exhaust air control (exhaust air sensor)	Room temperature control via exhaust air temperature sensor(s).	0
Potential-free group fault signalling contact forwarding to DDC/BUS	For forwarding the operating status (ON/OFF) and a control fault message (flashing).	•
Infinitely variable valve control for cold / heat	Actuation of the valve drives with a 0-10 V DC signal.	•
Continuous op. for the heating circuit pump	For non-insulated/long pipes.	•
External system start-up via the funct.: a) Switching ON/OFF b) Restricted system run time	via button or BUS The system will switch itself back off again automatically.	•
Flow temperature monitoring	Indirectly via the supply air temperature.	•
Op. modes "Day", "Night", "Off mode", "Standby"	Day (automatic), night (reduced operation), OFF mode (unoccupied periods), standby (OFF).	•
Heat recovery (WRG), cooling via WRG	Rotation-type (RWT) heat exch. (speed contr.) or PWT (bypass damper contr.), with 0-10 V DC act. signal.	•
E-heater bank	Actuation of an electric heater bank (on demand).	0
Holiday program	Additional time program on top of the above operating modes.	•
Summer time/winter time switching	Separate adjustment of the time by +/- one hour.	•
Defrost function PWT (icing sensor on the plate heat exchanger)	In the event of a risk of icing the bypass damper is opened and the PWT is defrosted by the warm exhaust air.	•
Minimum supply air limitation	Provided in all contr. unit versions; the supply air temp. will not drop below an adjust. limit.	•
Rapid ventilation	The fans run at full speed for a limited period	•
Outside temp. depend. speed reduction	If the outside temp. drops below an adjustable value the speed is reduced constantly	•

• Standard / 0 accessory



Fan diagrams / Pressure drop / Noise levels for KG-Kompakt 1500 (Precise selection via the computer program)

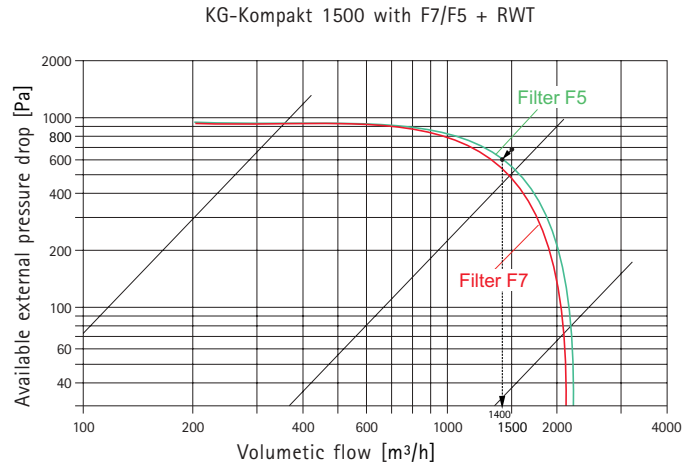
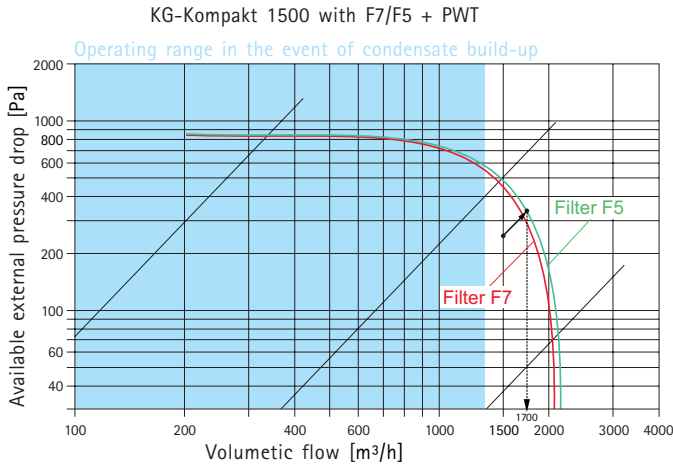

Example showing the configuration of a device
Air volume = 1500m³/h
KG-Kompakt 1500 with PWT
Exhaust air with filter F5

Channel pressure drop	suction side	110 Pa
	pressure side	90 Pa
Adaptor plate Ø 315 mm		62 Pa
Sum total of external pressure drop		262 Pa

The calculated operating point lies within the characteristic system curve.
At normal fan speeds, an actual operating air volume of approximately 1700 m³/h results from the characteristic system curve.
In the event of condensate build-up, the speed must be reduced enough so that the volumetric flow does not exceed 1350 m³/h.

Example showing the configuration of a device
Air volume = 1500m³/h
KG-Kompakt 1500 with RWT
Supply air with filter F7

Channel pressure drop	suction side	320 Pa
	pressure side	360 Pa
Heater		17 Pa
Sum total of external pressure drop		697 Pa

The calculated operating point lies outside the characteristic system curve.
At normal fan speeds, an actual operating air volume of 1400 m³/h results from the characteristic system curve.

Pressure drop

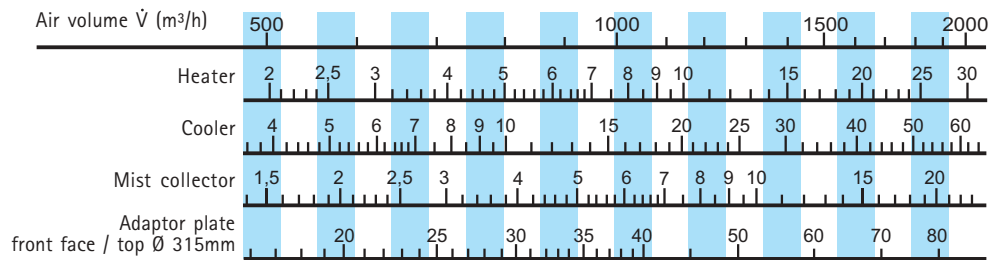

Note: The optional equipment "top blow-out" can only be fitted to versions with RWT

Noise level information

Volume flow (m ³ /h)	Noise level at ext. press. 100Pa		Noise level at ext. press. 200Pa		Noise level at ext. press. 300Pa		Noise level at ext. press. 400Pa		Noise level at ext. press. 500Pa	
	Lw dBA	Lp dBA	Lw dBA	Lp dBA	Lw dBA	Lp dBA	Lw dBA	Lp dBA	Lw dBA	Lp dBA
500	72	31	75	34	78	36	80	39	82	40
750	74	34	77	36	79	38	81	40	83	42
1000	77	36	79	38	81	40	83	41	84	43
1250	79	38	81	40	82	41	84	43	85	44
1500	81	40	83	41	84	43	85	44	86	45

The sound pressure level Lp dBA was measured under open-field conditions at a distance of 2 m from the device.
The sound power level Lw dBA is the sound power level being emitted by the fan.



Fan diagrams / Pressure drop / Noise levels for KG-Kompakt 2500 (Precise selection via the computer program)

KG-Kompakt 2500 with F7/F5 + PWT

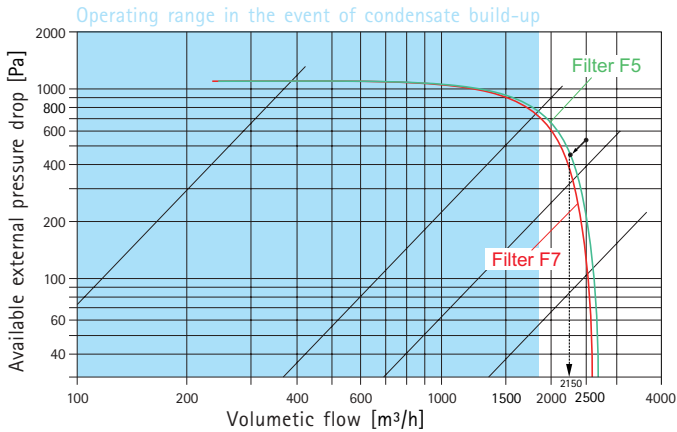

KG-Kompakt 2500 with F7/F5 + RWT

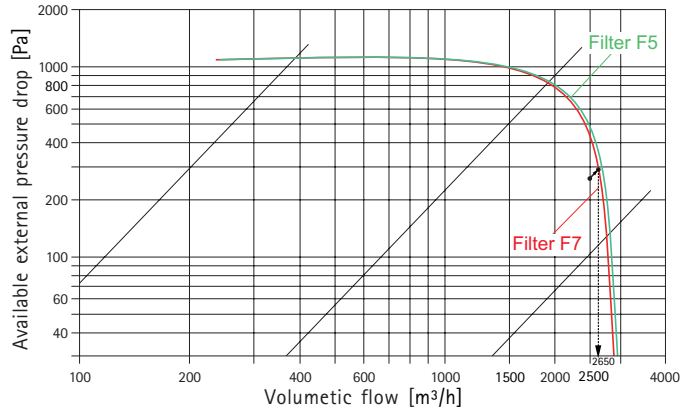

Example showing the configuration of a device
Air volume = 2500m³/h
KG-Kompakt 2500 with PWT
Exhaust air with filter F5

Channel pressure drop	suction side	250 Pa
	pressure side	180 Pa
Adaptor plate Ø 315 mm		110 Pa
Sum total of external pressure drop		540 Pa

Example showing the configuration of a device
Air volume = 2500m³/h
KG-Kompakt 2500 with RWT
Supply air with filter F7

Channel pressure drop	suction side	180 Pa
	pressure side	50 Pa
Heater		47 Pa
Sum total of external pressure drop		277 Pa

The calculated operating point lies outside the characteristic system curve. At normal fan speeds, an actual operating air volume of approximately 2150 m³/h results from the characteristic system curve. In the event of condensate build-up, the speed must be reduced enough so that the volumetric flow does not exceed 1900 m³/h.

The calculated operating point lies within the characteristic system curve. At normal fan speeds, an actual operating air volume of 2650 m³/h results from the characteristic system curve.

Pressure drop

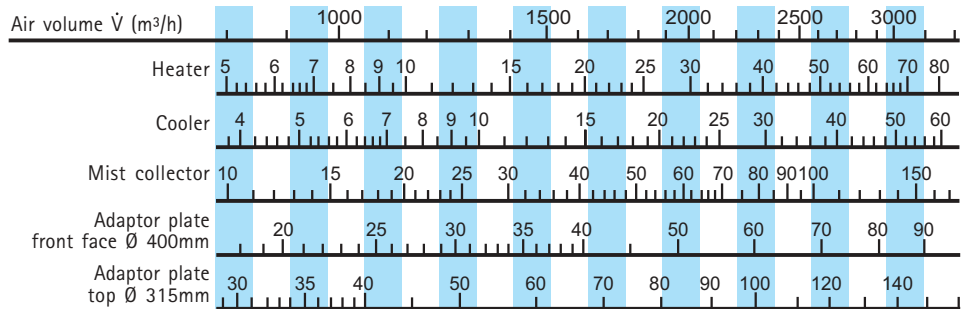

Note: The optional equipment "top blow-out" can only be fitted to versions with RWT

Noise level information

Volume flow (m³/h)	Noise level at ext. press. 100 Pa		Noise level at ext. press. 200 Pa		Noise level at ext. press. 300 Pa		Noise level at ext. press. 400 Pa		Noise level at ext. press. 500 Pa	
	Lw dBA	Lp dBA	Lw dBA	Lp dBA	Lw dBA	Lp dBA	Lw dBA	Lp dBA	Lw dBA	Lp dBA
1500	78	37	80	38	81	40	83	42	84	43
1750	80	39	81	40	83	42	84	43	85	44
2000	82	41	83	42	84	43	85	44	86	45
2250	84	43	85	44	86	44	87	45	87	46
2500	86	44	87	45	87	46	88	46	89	47

The sound pressure level Lp dBA was measured under open-field conditions at a distance of 2 m from the device. The sound power level Lw dBA is the sound power level being emitted by the fan.



Fan diagrams / Pressure drop / Noise levels for KG-Kompakt 4000

(Precise selection via the computer program)

KG-Kompakt 4000 with F7/F5 + KGXD

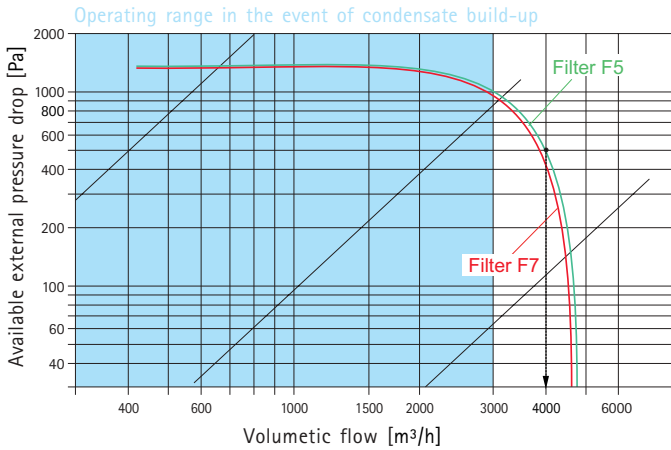

KG-Kompakt 4000 with F7/F5 + RWT

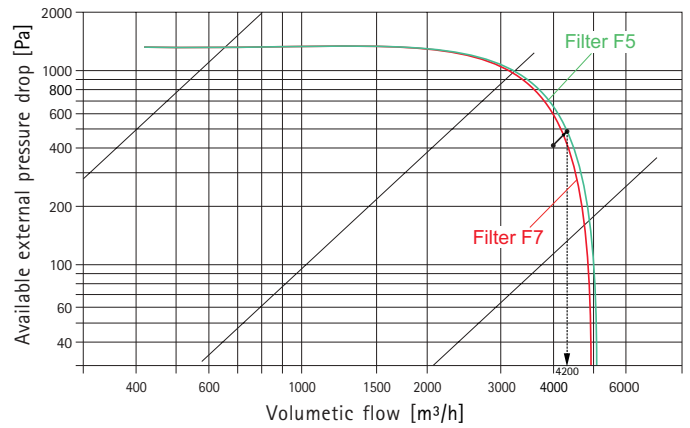

Example showing the configuration of a device
 Air volume = 4000m³/h
 KG-Kompakt 4000 with PWT
 Exhaust air with filter F5

Channel pressure drop	suction side	250 Pa
	pressure side	180 Pa
Adaptor plate Ø 500 mm		70 Pa
Sum total of external pressure drop		500 Pa

The calculated operating point lies on the characteristic system curve. At normal fan speeds, an actual operating air volume of 4000 m³/h results from the characteristic system curve. In the event of condensate build-up, the speed must be reduced enough so that the volumetric flow does not exceed 3000 m³/h.

Example showing the configuration of a device
 Air volume = 4000m³/h
 KG-Kompakt 4000 with RWT
 Supply air with filter F7

Channel pressure drop	suction side	150 Pa
	pressure side	150 Pa
Heater		35 Pa
Adaptor plate Ø 500		70 Pa
Sum total of external pressure drop		405 Pa

The calculated operating point lies within the characteristic system curve. At normal fan speeds, an actual operating air volume of 4200 m³/h results from the characteristic system curve.

Pressure drop

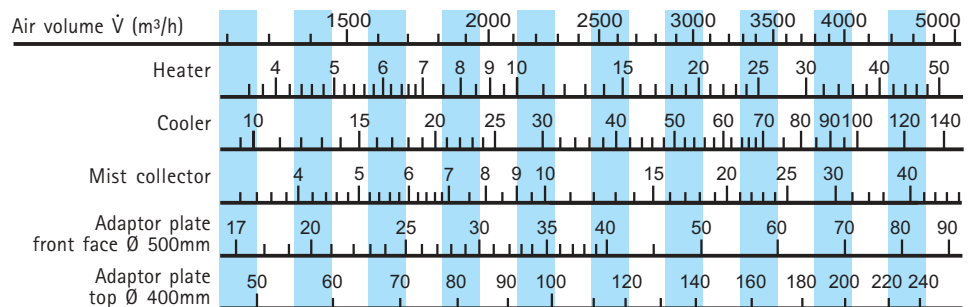

Note: The optional equipment "top blow-out" can only be fitted to versions with RWT

Noise level information

Volume flow (m³/h)	Noise level at ext. press. 100 Pa		Noise level at ext. press. 200 Pa		Noise level at ext. press. 300 Pa		Noise level at ext. press. 400 Pa		Noise level at ext. press. 500 Pa	
	Lw dBA	Lp dBA	Lw dBA	Lp dBA	Lw dBA	Lp dBA	Lw dBA	Lp dBA	Lw dBA	Lp dBA
2400	80	38	82	40	83	41	85	43	86	44
2800	82	40	84	42	85	43	86	44	87	45
3200	84	42	85	43	86	44	87	45	88	46
3600	86	44	87	45	88	46	89	47	89	47
4000	88	46	89	47	89	47	90	48	91	48

The sound pressure level Lp dBA was measured under open-field conditions at a distance of 2 m from the device. The sound power level Lw dBA is the sound power level being emitted by the fan.

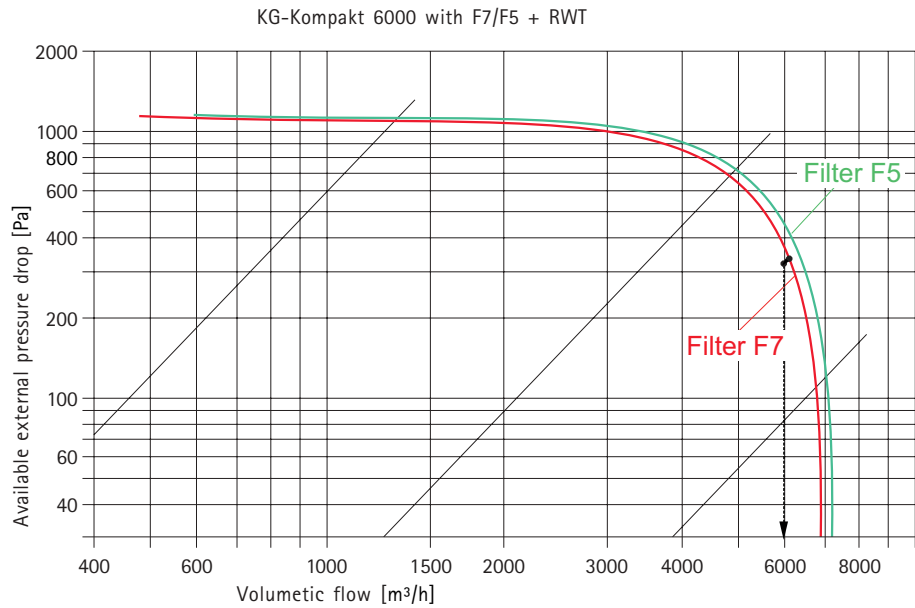

Example showing the configuration of a device
 Air volume = 6000m³/h
 KG-Kompakt 6000 with RWT
 Supply air with filter F7

Channel pressure drop	suction side	150 Pa
	pressure side	100 Pa
Heater		78 Pa
Sum total of external pressure drop		328 Pa

The calculated operating point lies within the characteristic system curve.
 At normal fan speeds, an actual operating air volume of 6100 m³/h results from the characteristic system curve.

Pressure drop

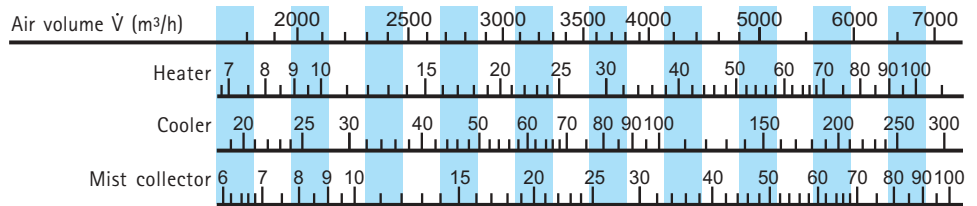

Noise level information

Volume flow (m ³ /h)	Noise level at ext. press. 100 Pa		Noise level at ext. press. 200 Pa		Noise level at ext. press. 300 Pa		Noise level at ext. press. 400 Pa		Noise level at ext. press. 500 Pa	
	Lw dBA	Lp dBA	Lw dBA	Lp dBA	Lw dBA	Lp dBA	Lw dBA	Lp dBA	Lw dBA	Lp dBA
3000	78	37	80	39	82	41	84	43	86	44
4000	82	40	83	42	85	43	86	45	87	46
5000	85	44	86	45	87	46	88	47	89	47
6000	88	46	89	47	90	48	91	49	90	49

The sound pressure level Lp dBA was measured under open-field conditions at a distance of 2 m from the device.
 The sound power level Lw dBA is the sound power level being emitted by the fan.

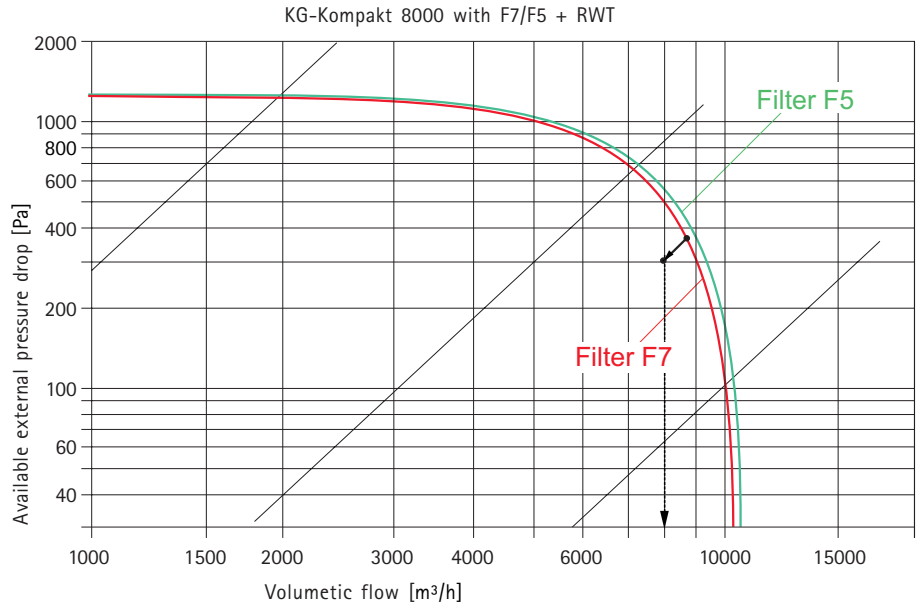

Example showing the configuration of a device
 Air volume = 8000m³/h
 KG-Kompakt 8000 with RWT
 Supply air with filter F7

Channel pressure drop	suction side	150 Pa
	pressure side	100 Pa
Heater		52 Pa
Sum total of external pressure drop		302 Pa

The calculated operating point lies within the characteristic system curve.
 At normal fan speeds, an actual operating air volume of 8600 m³/h results from the characteristic system curve.

Pressure drop

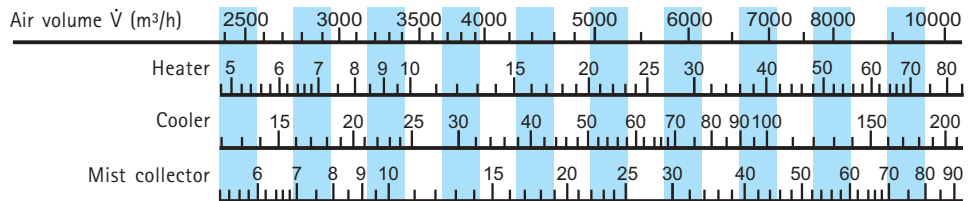

Noise level information

Volume flow (m ³ /h)	Noise level at ext. press. 100 Pa		Noise level at ext. press. 200 Pa		Noise level at ext. press. 300 Pa		Noise level at ext. press. 400 Pa		Noise level at ext. press. 500 Pa	
	Lw dBA	Lp dBA	Lw dBA	Lp dBA	Lw dBA	Lp dBA	Lw dBA	Lp dBA	Lw dBA	Lp dBA
5000	80	40	82	42	84	44	86	45	87	46
6000	83	42	84	44	86	45	87	46	88	47
7000	85	44	86	45	87	46	89	48	90	49
8000	87	46	88	47	89	48	90	49	91	50

The sound pressure level Lp dBA was measured under open-field conditions at a distance of 2 m from the device.
 The sound power level Lw dBA is the sound power level being emitted by the fan.

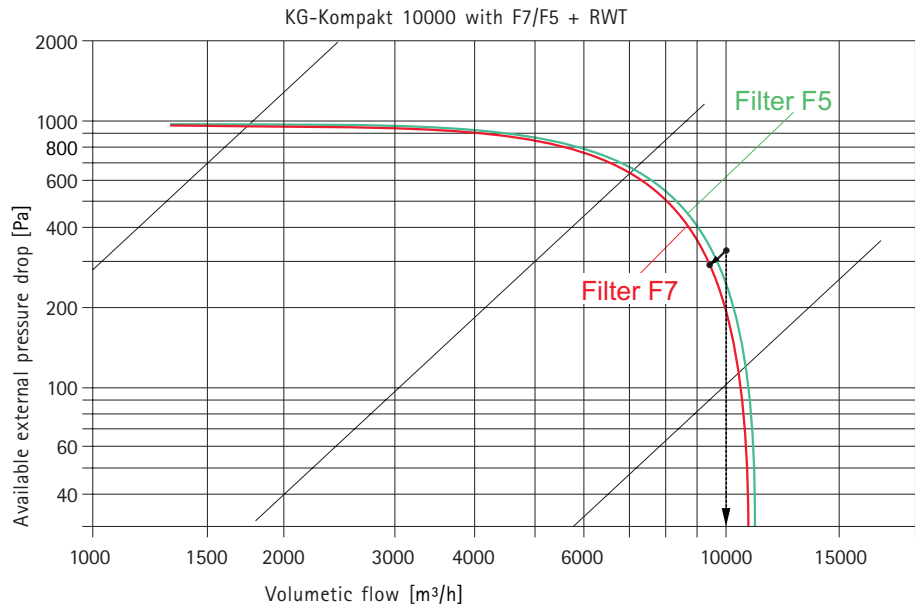

Example showing the configuration of a device
 Air volume = 10000m³/h
 KG-Kompakt 10000 with RWT
 Supply air with filter F7

Channel pressure drop	suction side	150 Pa
	pressure side	100 Pa
Heater		80 Pa
Sum total of external pressure drop		330 Pa

The calculated operating point lies outside the characteristic system curve.
 At normal fan speeds, an actual operating air volume of 9500 m³/h results from the characteristic system curve.

Pressure drop

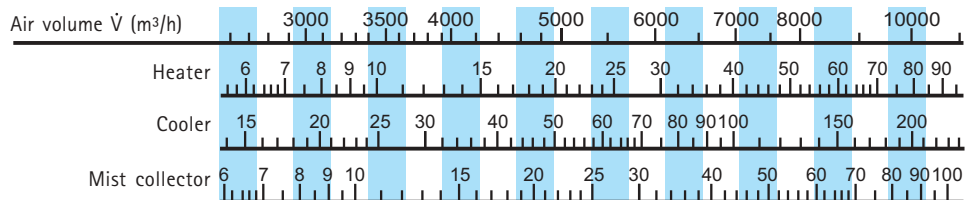

Noise level information

Volume flow (m³/h)	Noise level at ext. press. 100 Pa		Noise level at ext. press. 200 Pa		Noise level at ext. press. 300 Pa		Noise level at ext. press. 400 Pa		Noise level at ext. press. 500 Pa	
	Lw dBA	Lp dBA	Lw dBA	Lp dBA	Lw dBA	Lp dBA	Lw dBA	Lp dBA	Lw dBA	Lp dBA
7000	83	43	85	45	86	46	88	47	89	48
8000	85	44	86	46	88	47	89	48	90	49
9000	87	46	88	47	89	48	90	49	-	-
10000	88	47	89	48	-	-	-	-	-	-

The sound pressure level Lp dBA was measured under open-field conditions at a distance of 2 m from the device.
 The sound power level Lw dBA is the sound power level being emitted by the fan.

Heater section

Heat exchanger for low pressure hot water (LPHW)

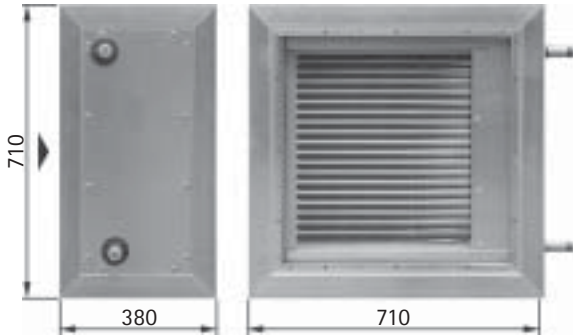

Equipment:

Heat exchanger with copper tubes and aluminium fins, header made of steel or alternatively copper

Connection diameter 3/4"

Water content 1 l

Permissible operating pressure 16 bar

Test pressure 30 bar

Water resistance (kPa)

$$\text{Water volume } w = \frac{0,86 \cdot \dot{Q}}{\Delta t_w} \quad (\text{m}^3/\text{h}) \quad \dot{Q} = \text{power in kW} \\ \Delta t_w = t_{WE} - t_{WA}$$

Water volume w (m³/h)

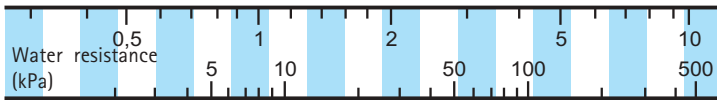

\dot{V} (m ³ /h)	1 600		2 400		
t_{WE} / t_{WA} °C / °C	t_{LE} °C	\dot{Q} kW	t_{LA} °C	\dot{Q} kW	t_{LA} °C
50/40	- 15	14,1	8	17,9	5
	- 10	12,7	11	16,1	8
	- 5	11,4	15	14,4	12
	± 0	10,1	18	12,8	15
	+ 5	8,8	21	11,1	18
	+ 10	7,5	24	9,5	21
	+ 15	6,2	27	7,9	25
+ 20	5,0	29	6,3	28	
70/50	- 15	17,0	13	21,5	9
	- 10	15,6	16	19,8	12
	- 5	14,3	20	18,1	16
	± 0	13,0	23	16,4	19
	+ 5	11,7	26	14,7	23
	+ 10	10,4	29	13,1	26
	+ 15	9,1	32	11,4	29
+ 20	7,8	35	9,8	32	
80/60	- 15	19,7	18	25,0	13
	- 10	18,3	21	23,2	16
	- 5	16,9	24	21,5	20
	± 0	15,6	27	19,8	23
	+ 5	14,3	30	18,1	27
	+ 10	13,0	34	16,4	30
	+ 15	11,7	37	14,8	33
+ 20	10,4	40	13,1	36	

Other operating conditions an request

Cooler

Heat exchanger for chilled water (Ch.w.)

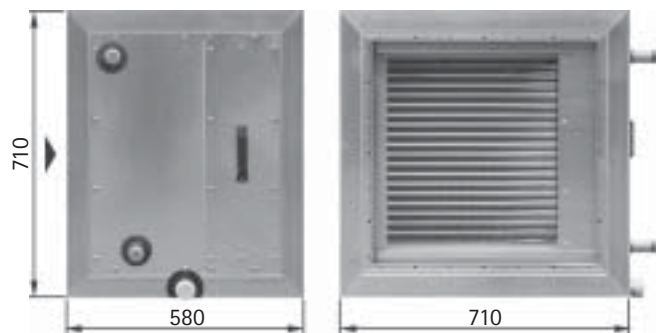

Equipment:

Chilled water exchanger with copper tubes and aluminium fins, header made of steel

Mist collector

Condensate pan with side condensate connection, male thread 1 1/4"

Connection diameter 1 1/4"

Water capacity 4,0 l

Permissible operating pressure 16 bar

Test pressure 30 bar

Note:

Always provide enough space to allow you to extract the exchanger.

Install a siphon at the condensate connection on-site.

Water resistance(kPa)

$$\text{Water volume } w = \frac{0,86 \cdot \dot{Q}}{\Delta t_w} \quad (\text{m}^3/\text{h}) \quad \dot{Q} = \text{capacity in kW} \\ \Delta t_w = t_{WE} - t_{WA}$$

Water volume w (m³/h)

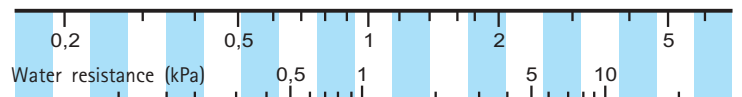

\dot{V} (m ³ /h)	1 600		2 400		
t_{WE} / t_{WA} °C / °C	t_{LE} °C	\dot{Q} kW	t_{LA} °C	\dot{Q} kW	t_{LA} °C
4/8	32	15,7	11,9	21,2	13,7
	28	13,2	11,4	17,8	12,9
	26	11,6	10,8	15,7	12,2
	25	10,9	10,5	14,6	11,9
5/10	32	14,0	13,1	18,9	14,7
	28	11,5	12,6	15,4	14,0
	26	9,9	12,0	13,3	13,3
	25	9,2	11,7	12,3	12,9
6/12	32	12,2	14,1	16,4	15,7
	28	9,8	13,6	13,0	14,9
	26	8,2	13,0	10,9	14,1
	25	7,5	12,7	9,9	13,7

Other operating conditions an request

Heater section

Heat exchanger for low pressure hot water (LPHW)

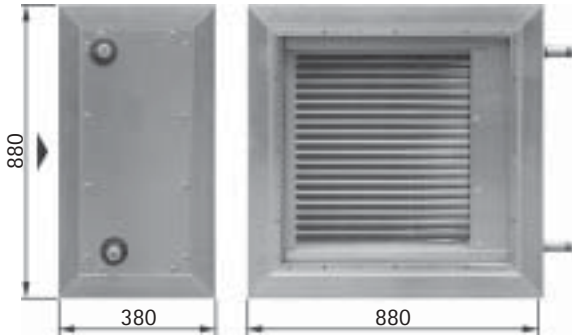

Equipment:

Heat exchanger with copper tubes and aluminium fins, header made of steel or alternatively copper

Connection diameter 1"

Water content 2,5 l

Permissible operating pressure 16 bar

Test pressure 30 bar

Water resistance (kPa)

$$\text{Water volume } w = \frac{0,86 \cdot \dot{Q}}{\Delta t_w} \quad (\text{m}^3/\text{h}) \quad \dot{Q} = \text{power in kW}$$

$$\Delta t_w = t_{WE} - t_{WA}$$

Water volume w (m³/h)



\dot{V} (m ³ /h)	2 500		3 700		5 000		6 300		
t_{WE} / t_{WA} °C / °C	t_{LE} °C	\dot{Q} kW	t_{LA} °C	\dot{Q} kW	t_{LA} °C	\dot{Q} kW	t_{LA} °C	\dot{Q} kW	t_{LA} °C
50/40	- 15	23,7	10	30,0	7	35,8	4	41,0	2
	- 10	21,5	13	27,2	10	32,5	8	37,1	6
	- 5	19,3	16	24,4	13	29,1	11	33,3	10
	± 0	17,1	19	21,7	16	25,8	14	29,5	13
	+ 5	15,0	22	19,0	20	22,6	18	25,7	17
	+ 10	12,9	25	16,3	23	19,4	21	22,1	20
	+ 15	10,8	28	13,6	26	16,2	25	18,4	24
+ 20	8,8	31	11,0	29	13,0	28	14,8	27	
70/50	- 15	28,9	16	36,6	11	43,6	8	49,7	6
	- 10	26,7	19	33,7	15	40,1	12	45,8	10
	- 5	24,5	22	30,9	18	36,8	15	42,0	13
	± 0	22,3	25	28,1	21	33,4	19	38,1	17
	+ 5	20,1	28	25,4	25	30,2	22	34,4	21
	+ 10	18,0	31	22,7	28	26,9	26	30,6	24
	+ 15	15,9	34	20,0	31	23,7	29	27,0	28
+ 20	13,8	37	17,3	34	20,5	32	23,3	31	
80/60	- 15	33,2	20	42,1	15	50,2	12	57,4	9
	- 10	31,0	23	39,2	19	46,8	15	53,4	13
	- 5	28,7	27	36,4	22	43,4	19	49,5	17
	± 0	26,5	30	33,6	25	40,0	22	45,7	20
	+ 5	24,3	33	30,8	29	36,7	26	41,9	24
	+ 10	22,2	36	28,0	32	33,4	29	38,1	28
	+ 15	20,1	39	25,3	35	30,1	33	34,4	31
+ 20	18,0	42	22,7	38	26,9	36	30,7	35	

Other operating conditions an request

Cooler

Heat exchanger for chilled water (Ch.w.)

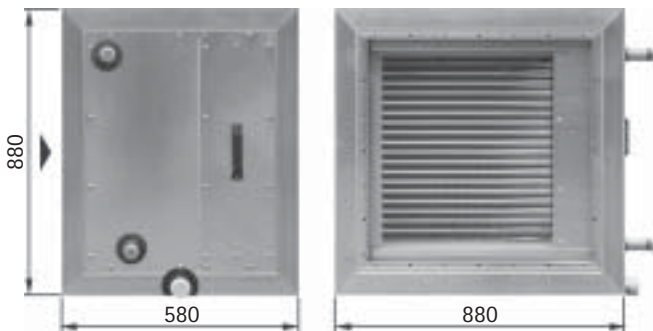

Equipment:

Chilled water exchanger with copper tubes and aluminium fins, header made of steel

Mist collector

Condensate pan with side condensate connection, male thread 1 1/4"

Connection diameter 1 1/2"

Water capacity 8,5 l

Permissible operating pressure 16 bar

Test pressure 30 bar

Note:

Always provide enough space to allow you to extract the exchanger. Install a siphon at the condensate connection on-site.

\dot{V} (m ³ /h)	2 500		3 700		5 000		6 300		
t_{WE} / t_{WA} °C / °C	t_{LE} °C	\dot{Q} kW	t_{LA} °C	\dot{Q} kW	t_{LA} °C	\dot{Q} kW	t_{LA} °C	\dot{Q} kW	t_{LA} °C
4/8	32	27,9	9,5	38,2	11,0	48,1	12,4	57,1	13,4
	28	23,7	9,2	32,3	10,6	40,5	11,7	47,9	12,7
	26	21,0	8,9	28,6	10,1	35,9	11,1	42,5	12,0
	25	19,6	8,7	26,7	9,9	33,6	10,8	39,7	11,6
5/10	32	25,2	10,7	34,4	12,2	43,2	13,5	51,1	14,5
	28	21,0	10,5	28,5	11,8	35,6	12,9	42,1	13,7
	26	18,3	10,1	24,8	11,3	31,0	12,3	36,6	13,0
	25	17,0	9,9	23,0	11,0	28,7	11,9	33,8	12,7
6/12	32	22,5	11,9	30,5	13,3	38,2	14,5	45,1	15,4
	28	18,3	11,7	24,6	12,9	30,7	13,9	36,1	14,7
	26	15,6	11,3	20,9	12,4	26,0	13,2	36,6	13,9
	25	14,2	11,1	19,1	12,1	23,7	12,9	27,9	13,5

Other operating conditions an request

Water resistance (kPa)

$$\text{Water volume } w = \frac{0,86 \cdot \dot{Q}}{\Delta t_w} \quad (\text{m}^3/\text{h}) \quad \dot{Q} = \text{power in kW}$$

$$\Delta t_w = t_{WE} - t_{WA}$$

Water volume w (m³/h)

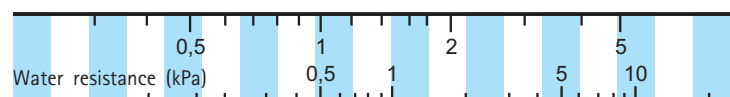

Heater section

Heat exchanger for low pressure hot water (LPHW)

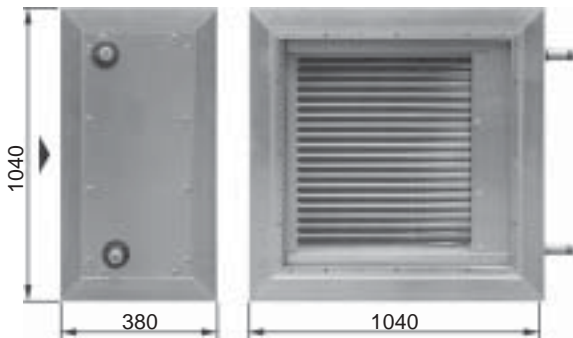

Equipment:

Heat exchanger with copper tubes and aluminium fins, header made of steel or alternatively copper

Connection diameter 1"

Water content 3,5 l

Permissible operating pressure 16 bar

Test pressure 30 bar

Water resistance (kPa)

$$\text{Water volume } w = \frac{0,86 \cdot \dot{Q}}{\Delta t_w} \quad (\text{m}^3/\text{h}) \quad \dot{Q} = \text{power in kW}$$

$$\Delta t_w = t_{WE} - t_{WA}$$

Water volume w (m³/h)



t_{WE} / t_{WA} °C / °C	t_{LE} °C	4 000		6 000		8 000		10 000	
		\dot{Q} kW	t_{LA} °C	\dot{Q} kW	t_{LA} °C	\dot{Q} kW	t_{LA} °C	\dot{Q} kW	t_{LA} °C
50/40	-15	38,8	11	49,6	7	58,8	4	66,9	3
	-10	35,2	14	44,9	10	53,2	8	60,6	6
	-5	31,6	17	40,3	14	47,7	11	54,3	10
	± 0	28,0	20	35,8	17	42,3	15	48,1	14
	+5	24,6	23	31,3	20	37,0	18	42,1	17
	+10	21,1	25	26,9	22	31,7	22	36,0	20
	+15	17,7	28	22,5	26	26,5	25	30,1	24
+20	14,3	31	18,2	29	21,4	28	24,2	27	
70/50	-15	47,3	16	60,4	12	71,4	9	81,2	7
	-10	43,7	20	55,7	15	65,8	12	74,8	10
	-5	40,1	23	51,0	18	60,3	16	68,5	14
	± 0	36,5	26	46,4	22	54,9	19	62,3	17
	+5	33,0	29	41,9	25	49,5	23	56,2	21
	+10	29,5	31	37,4	28	44,1	26	50,1	25
	+15	26,0	34	33,0	31	38,9	29	44,1	28
+20	22,6	37	28,6	34	33,7	33	38,1	31	
80/60	-15	54,3	21	69,5	16	82,3	12	93,7	10
	-10	50,6	24	64,7	19	76,7	16	87,3	14
	-5	47,0	27	60,0	23	71,1	19	80,9	17
	± 0	43,4	30	55,4	26	65,6	23	74,6	21
	+5	39,8	33	50,8	29	60,1	26	68,4	25
	+10	36,3	36	46,3	32	54,8	30	62,2	28
	+15	32,8	39	41,8	36	49,4	33	56,1	32
+20	29,4	42	37,4	39	44,2	37	50,1	35	

Other operating conditions an request

Cooler

Heat exchanger for chilled water (Ch.w.)

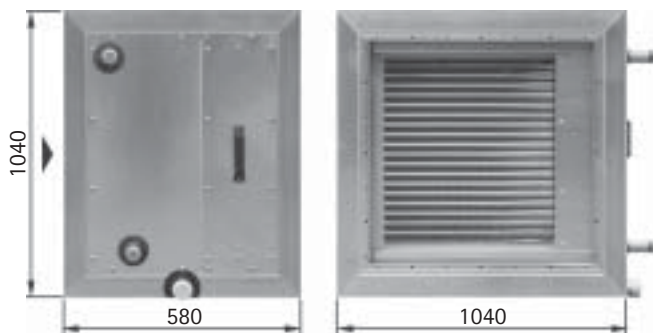

Equipment:

Chilled water exchanger with copper tubes and aluminium fins, header made of steel

Mist collector

Condensate pan with side condensate connection, male thread 1 1/4"

Connection diameter 2"

Water capacity 15 l

Permissible operating pressure 16 bar

Test pressure 30 bar

Note:

Always provide enough space to allow you to extract the exchanger.

Install a siphon at the condensate connection on-site.

t_{WE} / t_{WA} °C / °C	t_{LE} °C	4 000		6 000		8 000		10 000	
		\dot{Q} kW	t_{LA} °C	\dot{Q} kW	t_{LA} °C	\dot{Q} kW	t_{LA} °C	\dot{Q} kW	t_{LA} °C
4/8	32	43,7	10,2	60,1	11,9	74,6	13,2	87,8	14,3
	28	37,2	9,8	51,0	11,3	63,1	12,4	74,0	13,3
	26	33,1	9,3	45,4	10,7	56,2	11,7	65,9	12,5
	25	31,1	9,1	42,6	10,4	52,7	11,4	61,8	12,2
5/10	32	40,0	11,4	54,8	13,0	67,8	14,2	79,7	15,2
	28	33,4	11,0	45,6	12,4	56,3	13,5	66,0	14,3
	26	29,3	10,5	40,0	11,8	49,4	12,8	57,8	13,5
	25	27,3	10,3	37,2	11,5	45,9	12,4	53,8	13,1
6/12	32	36,1	12,5	49,3	14,0	60,9	15,2	71,4	16,1
	28	29,5	12,1	40,1	13,4	49,4	14,4	57,8	15,2
	26	25,4	11,6	34,5	12,8	42,5	13,7	49,7	14,4
	25	23,4	11,4	31,7	12,5	39,0	13,3	45,6	13,9

Other operating conditions an request

Water resistance (kPa)

$$\text{Water volume } w = \frac{0,86 \cdot \dot{Q}}{\Delta t_w} \quad (\text{m}^3/\text{h}) \quad \dot{Q} = \text{power in kW}$$

$$\Delta t_w = t_{WE} - t_{WA}$$

Water volume w (m³/h)



Dimensions

Single enclosure with RWT	KG-Kompakt	1500	2500	4000
	Length (mm)	1750	1750	1950
	Width (mm)	755	960	1060
	Height (w/o repair switch*) (mm)	1425	1425	1425
	Weight (kg)	354	408	482
	Volumetric flow (m ³ /h) at max. ext. pressure 500 Pa	1500	2500	4000
	Volumetric flow (m ³ /h) at max. ext. pressure 200 Pa	1800	2800	4400

Single enclosure with PWT/KGXD	KG-Kompakt	1500	2500	4000
	Length (mm)	1950	1950	2160
	Width (mm)	755	960	960
	Height (w/o repair switch*)(mm)	1425	1425	1425
	Weight (kg)	357	412	538
	Volumetric flow (m ³ /h) at max. ext. pressure 200 Pa	1500	2500	4000
	Max. volumetric flow (m ³ /h) with condensate build-up	1350	1900	3000

Split version	KG-Kompakt	6000	8000	10000
	Length (mm)	2150 (820+510+820)	2350 (920+510+920)	2350 (920+510+920)
	Width (mm)	1360	1670	1670
	Height (w/o repair switch*)(mm)	1425	1625	1625
	Weight (kg)	590	940	970
	Volumetric flow (m ³ /h)	6000	8000	10000

Technical selection available on request Repair switch +113mm

Motor specification

KG-Kompakt	1500	2500	4000	6000	8000	10000
Rated voltage	400V / 50Hz / Y	400V / 50Hz / Y	400V / 50Hz / Y	400V / 50Hz / Y	400V / 50Hz / Y	400V / 50Hz / Y
Rated power	0,75 kW	1,10 kW	2,20 kW	3,00kW	4,00 kW	4,00 kW
Rated current	1,8 A	2,6 A	4,8 A	6,4 A	8,3 A	8,3 A
Rated speed	2850 rpm	2850 rpm	2880 rpm	1420 rpm	1440 rpm	1440 rpm
Protection	IP 55	IP 55	IP 55	IP 55	IP 55	IP 55
Max. frequency	64 Hz	73 Hz	64 Hz	93 Hz	70 Hz	59 Hz
Max. speed	3700 rpm	4200 rpm	3690 rpm	2650 rpm	2030 rpm	1710 rpm

Airtight damper

Suction on the front face for fresh air or exhaust air in accordance with DIN EN 1751, class 2, installed on the unit.

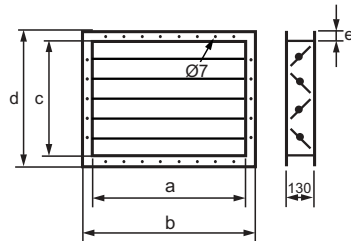
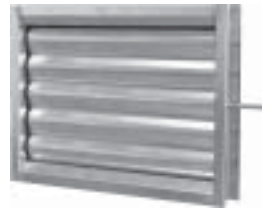

Suction on the front face

KG-Kompakt	a	b	c	d	e
1500 RWT/PWT	572	648	572	648	38
2500 RWT/PWT	775	851	572	648	38
4000 RWT	877	953	572	648	38
4000 KGXD	775	851	572	648	38
6000 RWT	1182	1258	572	648	38
8000 RWT	1487	1563	572	648	38
10000 RWT	1487	1563	572	648	38

Open/Close actuator motor

for 230 V/50 Hz damper, with linkage and actuating lever, installed on the unit.



Actuator motor with spring return

for 230 V/50 Hz damper, with linkage and actuating lever, installed on the unit.



Canvas flange

Suction or blow-out on front face for fresh air or exhaust air, installed on the unit.

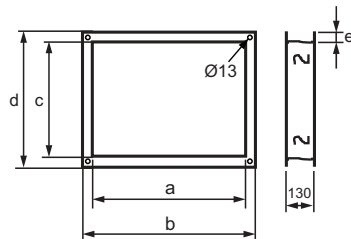

Suction/blow-out on front face

KG-Kompakt	a	b	c	d	e
1500 RWT/PWT	588	646	588	646	29
2500 RWT/PWT	791	849	588	646	29
4000 RWT	893	951	588	646	29
4000 KGXD	791	849	588	646	29
6000 RWT	1200	1258	588	646	29
8000 RWT	1505	1563	588	646	29
10000 RWT	1505	1563	588	646	29

Top blow-out

KG-Kompakt	a	b	c	d	e
1500 RWT	400	458	400	458	29
2500 RWT	700	758	400	458	29
4000 RWT	700	758	530	588	29

Note: the optional equipment "top blow-out" can only be fitted to versions with RWT and up to size KG-Kompakt 4000

Adaptor plate

for round duct connections to existing ducts.
Suction or blow-out on front face for fresh air or exhaust air, installed on the unit.

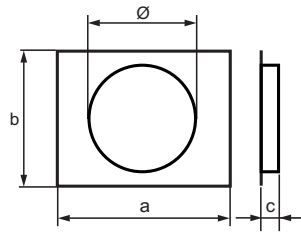

Note: The optional equipment "top blow-out" can only be fitted to versions with RWT

Suction / blow-out on front face

KG-Kompakt	Ø	a	b	c
1500 RWT/PWT	315	648	648	62
2500 RWT/PWT	400	851	648	62
4000 RWT	500	953	648	62
4000 KGXD	500	851	648	62

Top blow-out

KG-Kompakt	Ø	a	b	c
1500 RWT	315	458	458	62
2500 RWT	315	758	458	62
4000 RWT	400	758	558	62

Copper/aluminium heater

suitable for low pressure hot water for downstream air heating incl. enclosure.

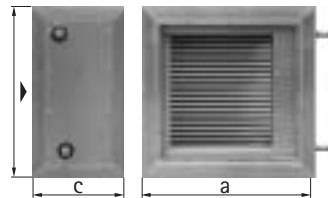

KG-Kompakt	a	b	c
1500	710	710	380
2500	710	710	380
4000	880	880	380
6000	880	880	380
8000	1040	1040	380
10000	1040	1040	380

Copper/aluminium cooler,

suitable for chilled water for downstream air cooling incl. enclosure, mist collector and pan.

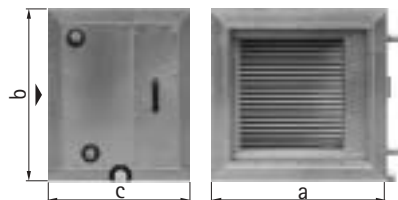

KG-Kompakt	a	b	c
1500	710	710	580
2500	710	710	580
4000	880	880	580
6000	880	880	580
8000	1040	1040	580
10000	1040	1040	580

Electric heater bank

for downstream air heating incl. enclosure on request.

Canvas flange

for downstream banks.

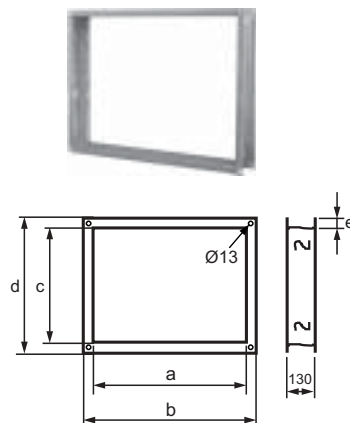

KG-Kompakt	a	b	c	d	e
1500	530	588	530	588	29
2500	530	588	530	588	29
4000	700	758	700	758	29
6000	700	758	700	758	29
8000	860	920	860	920	29
10000	860	920	860	920	29

Constant pressure regulator
comprising: 2 pressure sensors
(fitted)



Volume flow control unit
comprising: 2 pressure sensors
(fitted)

Programming unit LCP-2
for an individual adjustment of
different parameters of the
installation consisting of the KG-
Kompakt and the ductwork system



Pressure sensor (loose)



Radio clock module
for synchronising the clock with the
DCF transmitter



**Wireless clock module with
outside temperature sensor**
for synchronising the internal clock
with the DCF transmitter and for
capturing the outside temperature



**Outside temperature sensor
QAC22**
Mandatory requirement for heat
recovery



**Wireless outside temperature
sensor**
(only available in conjunction with
receiver for wireless outside
temperature sensor,
part. no. 27 44 082)



**Receiver for wireless outside
temperature sensor**
incl. DCF (radio-controlled clock)



**Extract air sensor QAM
9120.040**
for supply air/extract air
temperature control unit, icing
sensor



Room temperature sensor QAA24
for room temperature control unit



**Room temperature sensor with
set temperature encoder QAA26**
for room temperature control unit



Frost stat



ISDN interface
for communication from the
programming unit to the mobile
network; notification of "system
errors" by text to a mobile phone
or a PC

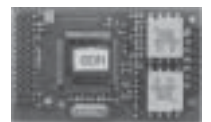

LON Gateway
A LON network can check the
operating modes via an interface
(available from Dec. 2005)



Heat recovery rate Φ with RWT

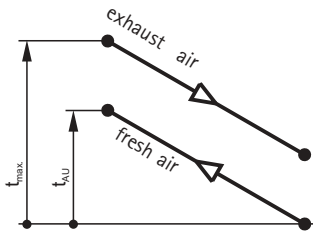

$$\Delta t_{AU} = \frac{\Phi}{100} \times \Delta t_{max}$$

(fresh air temperature increase)

$$\Phi = \Phi_0 + \Phi_1$$

$\Phi_0 = 78\%$ (basic heat recovery rate)

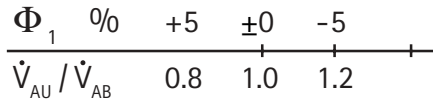

Maximum achievable heat recovery rate (dry) = 85%

Heat recovery rate Φ for KG-Kompakt 1500/2500 with PWT

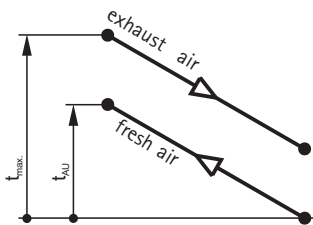

$$\Delta t_{AU} = \frac{\Phi}{100} \times \Delta t_{max}$$

(fresh air temperature increase)

$$\Phi = \Phi_0 + \Phi_1$$

$\Phi_0 = 80\%$ (basic heat recovery rate)

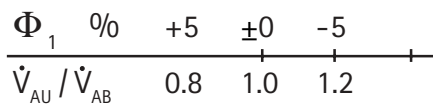

Maximum achievable heat recovery rate (dry) = 85%

Heat recovery rate Φ for KG-Kompakt 4000 with KGXD

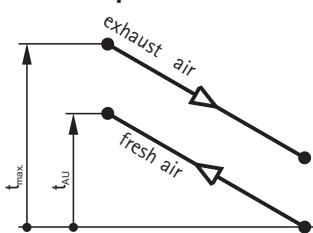

$$\Delta t_{AU} = \frac{\Phi}{100} \times \Delta t_{max}$$

(fresh air temperature increase)

$$\Phi = \Phi_0 + \Phi_1$$

$\Phi_0 = 55\%$ (basic heat recovery rate)

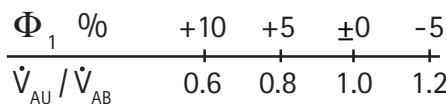

Maximum achievable heat recovery rate (dry) = 65%

Example: KG-Kompakt 1500 with RWT, at $\dot{V}_{Fresh\ air} / \dot{V}_{Exhaust\ air} = 1500/1350 = 1.1$

The heat recovery rate is $\Phi = 78\% + (-2.5\%) = 75.5\%$ (≈ 0.75)

At an extract air temperature of +25°C and a outside temperature of -10°C and +25 - (-10) = 35K. Consequently, the fresh air can be heated from -10°C + (35 K x 0.75) = -10 + 26 = to +16°C.

Item	Qty.		Unit price	Total price																				
		<p>KG-Kompakt – Air handling unit with heat recovery Compact combined ventilation and extraction unit with integral heat recovery as rotating storage mass or, alternatively, either with a high efficiency countercurrent or crossflow heat exchanger. Available external pressing up to 500 Pa Equipment fully wired for quick and easy commissioning External central equipment switch for the highest level of safety during maintenance and repair work.</p> <p>Enclosure Compact, robust profile frame construction with special copper/aluminium weld seams for complete hot dip galvanizing of the frame after welding and for permanent corrosion protection of the enclosure.</p> <p>Duplex enclosure construction made from sheet steel (zinc-plated on both sides) with sandwiched insulation. Heat transition coefficient $k = 0.6$ (W/m²K), sound insulation factor $R_w = 41$ dB to DIN/EN ISO 717, part 1.</p> <p>Optimum sound and thermal insulation through 50 mm thick mineral wool, material class A1, non-combustible to DIN 4102. Thermal conductivity 0.04 W/mk.</p> <p>The internal surfaces of the KG-Kompakt with heat recovery are absolutely smooth. The floor of the enclosure is free of gaps for perfect cleaning and meets the highest requirements for hygienic air handling unit design.</p> <p>Full-height inspection doors covering the entire operating height of the equipment ensure easy access to the internal components.</p> <p>Thermal transfer class ($K = 1.3$) = T3, thermal bridge class ($K_b = 0.45$) = TB3, filter bypass leakage rate < 2%, enclosure soundness: soundness class B, mechanical stability: enclosure class 1A.</p> <table border="1"> <thead> <tr> <th>Integration insulation De value of the enclosure</th> <th>Hz</th> <th>125</th> <th>250</th> <th>500</th> <th>1000</th> <th>2000</th> <th>4000</th> <th>8000</th> <th>Σ</th> </tr> </thead> <tbody> <tr> <td></td> <td>dB</td> <td>20.8</td> <td>26.6</td> <td>30.0</td> <td>29.4</td> <td>31.2</td> <td>34.2</td> <td>35.9</td> <td>30.7</td> </tr> </tbody> </table> <p>Fan motor unit for supply air and extract air Free-wheeling, energy-optimised fan impeller, unilateral inlet, with rearward-curved impeller vanes, mounted directly on the motor shaft, powder-coated for surface protection, fan nozzle with integral brass fitting for directing the volume flow. Complete unit mounted on a robust base frame, flexibly fitted to anti-vibration mounts</p> <p>Impeller statically and dynamically balanced to DIN ISO 1940 part 1, high balance quality, motor fan unit balanced; permiss. vibration less than 2.8 mm/s to DIN ISO 14694.</p> <p>High fan efficiency over its entire speed range, even with low pressing and high volume flow rates.</p> <p>Dynamic pressure proportions are largely converted by the ring diffuser into useful pressure.</p> <p>In conjunction with the inverter, it is possible to accurately match the required air volume to the system curve.</p> <p>Highest EMC class through inverter mounted directly to the motor housing, resulting in the absence of interfering electro-magnetic radiation on the exterior of the equipment.</p> <p>Motors suitable for three-phase power as standard; IP 55, type IMB3.</p> <p>Standard thermal motor protection through PTC resistor, thermal class F.</p> <p>Economical and energy-efficient operation through the lowest electrical power consumption.</p> <p>Low maintenance requirement.</p>	Integration insulation De value of the enclosure	Hz	125	250	500	1000	2000	4000	8000	Σ		dB	20.8	26.6	30.0	29.4	31.2	34.2	35.9	30.7		
Integration insulation De value of the enclosure	Hz	125	250	500	1000	2000	4000	8000	Σ															
	dB	20.8	26.6	30.0	29.4	31.2	34.2	35.9	30.7															

Item	Qty.		Unit price	Total price
		<p>Filter</p> <p>Supply air filter: pocket filter, class F7.</p> <p>Exhaust air filter: pocket filter, class F5 (on request: F7).</p> <p>Standard with integral filter monitor for supply air and exhaust air.</p> <p>Heat recovery</p> <p>KG-Kompakt 1500, 2500, 4000, 6000, 8000 and 10000</p> <p>Integral rotation-type heat exchanger (RWT) with optimum impeller geometry and low pressure drop for the highest heat recovery rate (up to 85% dry).</p> <p>The rotor speed can be matched to any demand through an infinitely variable speed control.</p> <p>Functions, such as automatic interval operation, rotation limiter with rotation encoder, alarm relays, ramp-up and delay ramp, motor brake during idle times, priority switch/defrost.</p> <p>KG-Kompakt 1500 and 2500:</p> <p>Heat recovery via high performance countercurrent heat exchanger PWT made from corrosion-resistant aluminium for the highest heat recovery rates (up to 85% dry); standard with motorised (24 V) airtight bypass damper to DIN EN 1751, class 2.</p> <p>KG-Kompakt 4000:</p> <p>Heat recovery via crossflow heat exchanger KGXD made from corrosion-resistant aluminium for heat recovery rates (up to 65%); standard with motorised (24 V) airtight bypass damper to DIN EN 1751, class 2.</p> <p>Accessories</p> <p>Airtight damper</p> <p>End inlets for fresh and extract air to DIN EN 1751, class 2 assembled on the equipment</p> <p>KG-Kompakt 1500 RWT/PWT KG-Kompakt 2500 RWT/PWT, KG-Kompakt 4000 KGXD KG-Kompakt 4000 RWT KG-Kompakt 6000 RWT KG-Kompakt 8000 RWT KG-Kompakt 10000 RWT</p> <p>Actuator open/close 230 V/50 Hz with spring return for damper, with linkage and [manual] actuator lever.</p> <p>Actuator open/close 230 V/50 Hz with damper, with linkage and [manual] actuator lever.</p> <p>Canvas flange</p> <p>End inlet and outlet; for fresh or extract air fitted to the equipment</p> <p>KG-Kompakt 1500 RWT/PWT KG-Kompakt 2500 RWT/PWT, KG-Kompakt 4000 KGXD KG-Kompakt 4000 RWT KG-Kompakt 6000 RWT KG-Kompakt 8000 RWT KG-Kompakt 10000 RWT</p> <p>Canvas flange</p> <p>Outlet above for supply or extract air fitted to the equipment</p> <p>KG-Kompakt 1500 RWT KG-Kompakt 2500 RWT KG-Kompakt 4000 RWT</p> <p>Canvas flange for bank installed downstream</p> <p>KG-Kompakt 1500/2500 KG-Kompakt 4000/6000 KG-Kompakt 8000/10000</p> <p>Adaptor plate for round duct connection on site ducts</p> <p>KG-Kompakt 1500 RWT/PWT (Ø 315 mm) KG-Kompakt 2500 RWT/PWT (Ø 400 mm)</p> <p>End inlet and outlet for fresh or extract air, fitted to the equipment</p> <p>KG-Kompakt 4000 RWT (Ø 500 mm) KG-Kompakt 4000 KGXD (Ø 500 mm)</p> <p>Adaptor plate for round duct connection on site ducts</p> <p>KG-Kompakt 1500 RWT (Ø 315 mm) KG-Kompakt 2500 RWT (Ø 315 mm)</p> <p>Inlets above for fresh or extract air fitted to the equipment</p> <p>KG-Kompakt 4000 RWT (Ø 400 mm)</p> <p>Heater made from copper/aluminium for air heating downstream, incl. enclosure.</p> <p>Cooler made from copper/aluminium for air cooling downstream, incl. enclosure, mist collector and condensate pan.</p> <p>Electrical heater bank for air heating downstream, incl. enclosure (upon request).</p>		

Item	Qty.		Unit price	Total price
		<p>Control unit</p> <p>Factory-fitted and fully wired, programming unit supplied loose, therefore also suitable as remote control unit. Control panel for control and regulating elements, integrated in the equipment. Functions: fault statistics; mixer/pump protection; up to eight zones can be controlled with a single programming unit; LON gateway; radio clock; eBUS; wireless outside temperature sensor; external connections via plug (Plug & Play); up to eight switching times per day may be selected; balance adjustment between supply air and extract fan. Operation via programming unit with display panel, incl. LCD and clock display. Temperature control with variable speed.</p>		
		<p>Control unit accessories</p> <p>Constant pressure regulation (consisting of two fitted pressure sensors) Volume flow control unit (consisting of two fitted pressure sensors) Programming unit LCP-2 for the adjustment of the installation including the ductwork system Pressure sensor (loose) Radio clock module for synchronising the internal clock with the DCF transmitter Radio clock module with outside temperature sensor for synchronising the internal clock with the DCF transmitter and for capturing the outside temperature Outside temperature sensor QAC22 for night cooling and heat recovery Wireless outside temperature sensor (only in conjunction with receiver for wireless outside temperature sensor) Receiver for wireless outside temperature sensor incl. DCF (radio clock) Extract air sensor QAM 9120.040 for supply air/extract air temperature control unit, icing sensor Room temperature sensor QAA24 for room temperature control unit Room temperature sensor with set temperature encoder QAA26 for room temperature control unit Frost stat ISDN interface for reporting faults as text to a mobile phone or PC LON gateway for reading operating data via a LON network, from Dec. 2005</p>		
		<p>Specification</p> <p>Volume flow m³/h Available ext. pressure drop Pa Fan speed min Fan rating kW Operating voltage 400 V</p> <p>Dimensions Length: mm Width: mm Height mm Weight mm</p> <p>Make Wolf</p> <p>Equipment type: KG-Kompakt</p>		

The comprehensive equipment range from system supplier Wolf offers the ideal solution for commercial and industrial buildings, for new build and modernisation projects alike. The Wolf control unit range fulfils every need where heating convenience is concerned.

The products are easy to operate, energy efficient and reliable. Photovoltaic and solar heating systems can be quickly integrated into existing systems.

All Wolf products can be easily and rapidly assembled and maintained.

Wolf GmbH, PO Box 1380, 84048 Mainburg, Tel.: 0 87 51 / 74-0, Fax: 0 87 51 / 74-1600, Internet: www.wolf-heiztechnik.de

System example - shopping centre

► Air handling system components

- KGW Gigant
- KGW Gigant with integral cooling technology
- KGG Garage air extractor
- KGW Gigant kitchen extractor
- KGW Standard
- KG Standard, flat air conditioning unit

► Ventilation system components

- ER smoke extractor fan
- Hot air curtain heater with mounting bracket, white TL
- Air conditioning unit (freestanding)
- LH air heater
- DigiPro control unit

► Heating system components

- Cast iron boiler MK 2



The true professional for heating, air conditioning, ventilation and solar heating systems

