



Technik, die dem Menschen dient.

TopWing - Air heater TLHD





The TLHD unit is extremely quiet and in combination with the continuous speed control, the TopWing concentrates on the essential while reducing noise.

The air heaters in series TopWing have a modern, attractive design, the harmonious, soft outline of which is shown to its best advantage in showrooms, entrance halls, sales floors, or supermarkets. The light colour in white RAL 9016 and the rounded edges let the TopWing device blend in on ceilings.

Depending upon installation conditions, circulating air or mixed air is drawn in from above and blown out in six directions. Since the devices are suitable for heating or cooling, the air distribution always provides a pleasant room climate, both in the summer and in winter. As motor/fan unit, an ultra-quiet crescent wing with a single phase motor 230 V is used. Alternatively, a motor/fan unit with 3x400V motor is available. Regardless of which motor/fan unit was selected, the speed can be controlled continuously with the corresponding controls in the product range. As the heating or cooling application, a Cu/Al register with three pipe rows is used for TopWing. This has the advantage that with low-temperature heaters or condensation heating systems with supply/return spreading of 50/40 °C and a maximum volume flow in operation with circulating air, exhaust temperatures of approx. 34 °C can be reached.

With the extremely quiet crescent wing and in combination with the continuous speed control, the TopWing concentrates on the essential while reducing noise. See for yourself:

TopWing warms without being noisy.



With the associated digital controls, both motor fan units can be speed-controlled continuously. The controller adapts the speed automatically in such a way that the set room temperature is kept.



As the heating or cooling application, a Cu/Al register with three pipe rows is used for TopWing. This has the advantage that with low-temperature heaters or condensation heating systems with supply/return spreading of 50/40 °C and a maximum volume flow in operation with circulating air, exhaust temperatures of approx. 34 °C can be reached.

TLHD mounted on false ceiling



Air heater for the installation on ceiling for operation with circulating air or to a false ceiling for circulating air or mixed air operation.

2 unit sizes:

Heating: Air volume up to 4600 m³/h. Heating power 57 kW

Cooling: Air volume up to 3600 m³/h. Cooling capacity 21,3 kW

Modern attractive design, housing in powder-coated design, white RAL 9016.

Can be used on sales floors, in supermarkets, furniture stores, etc.

Adjustable blow-out lamellas.

Heat exchanger up to PN 16 made of Cu/Al with 3 pipe rows up to 90°C for PWW, PKW; two-lead system for heating or cooling; heating operation with low-temperature heaters and/or condensation heating systems possible.

TLHD mounted on ceiling

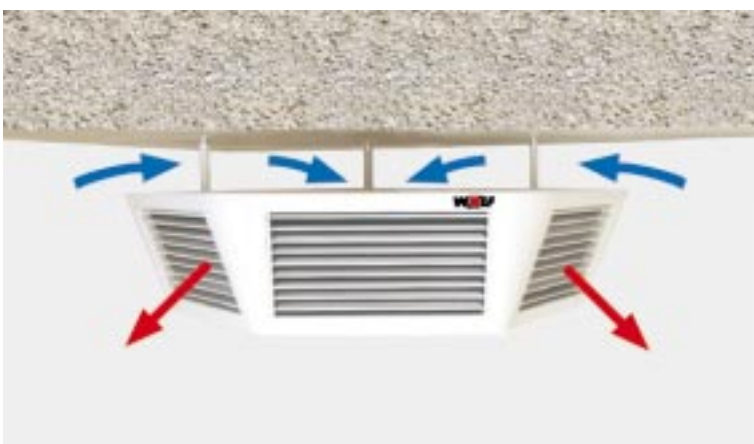

Single-phase motor 230V / 50Hz as external rotor motor with thermal contacts, with crescent wing, extremely quietly.

alternative: Three-phase motor 3 x 400V / 50Hz with impeller.

For cooling models, also with condensate basin, float switch, condensate pump, control unit, and drain hose.

TopWing Air heater Performance Heating/Cooling TLHD

	Type		TLHD 40							
	Speed		900 min ⁻¹		700 min ⁻¹		500 min ⁻¹		300 min ⁻¹	
	Volume flow		2100 m ³ /h		1600 m ³ /h		1200 m ³ /h		700 m ³ /h	
	t _{LE} °C	Q kW	t _{LA} °C	Q kW	t _{LA} °C	Q kW	t _{LA} °C	Q kW	t _{LA} °C	
Heating	PWW 50/40	5	17.1	28	14.1	30	11.6	32	7.7	36
		10	14.7	30	12.2	32	9.9	34	6.7	38
		15	12.3	32	10.3	34	8.4	36	5.6	39
		20	9.9	34	8.3	36	6.8	37	4.6	40
	PWW 60/50	5	21.7	35	18.0	37	14.6	40	9.7	44
		10	19.3	37	16.0	39	13.0	41	8.6	46
		15	16.9	39	14.0	41	11.4	43	7.6	47
		20	14.6	41	12.1	43	9.9	45	6.6	48
	PWW 70/50	5	22.9	36	19.0	39	15.5	42	10.4	48
		10	20.5	38	17.0	41	13.9	44	9.4	49
		15	18.1	40	15.1	43	12.3	45	8.3	50
		20	15.7	42	13.1	45	10.8	47	7.3	51
PWW 80/60	5	27.6	42	22.9	46	18.6	49	12.4	55	
	10	25.2	45	20.9	48	17.0	51	11.3	57	
	15	22.8	47	18.9	50	15.4	53	10.3	58	
	20	20.4	49	16.9	52	13.8	55	9.3	60	
Cooling	PKW¹⁾ 10/16	32	7.8	21	6.6	20	5.4	19	3.7	17
		30	6.8	20	5.7	19	4.6	18	3.2	17
		28	5.9	19	4.9	19	4.0	18	2.7	16
		26	4.9	19	4.1	18	3.4	17	2.3	16
		25	4.4	19	3.7	18	3.0	17	2.0	16
	Speed		900 min ⁻¹		700 min ⁻¹		400 min ⁻¹		150 min ⁻¹	
	Volume flow		1600 m ³ /h		1200 m ³ /h		700 m ³ /h		250 m ³ /h	
	PKW 5/10	32	10.0	18	8.3	17	5.6	15	2.5	11
		30	9.1	18	7.5	17	5.1	15	2.3	11
		28	8.2	17	6.8	16	4.6	14	2.1	11
		26	7.2	16	5.9	15	4.1	13	1.8	10
		25	6.7	15	5.5	15	3.8	13	1.7	10
	PKW 6/12	32	8.9	19	7.3	18	5.0	16	2.3	12
		30	8.0	18	6.6	17	4.5	15	2.0	12
		28	7.1	18	5.9	17	4.0	15	1.7	12
		26	6.1	17	5.0	16	3.5	14	1.5	12
		25	5.5	16	4.6	15	3.2	14	1.4	11
	PKW 8/14	32	7.8	20	6.4	19	4.4	17	1.9	14
		30	6.8	19	5.6	18	3.9	16	1.6	14
		28	6.0	18	4.9	17	3.4	16	1.4	13
26		4.9	17	4.1	16	2.8	15	1.3	13	
25		4.5	17	3.7	16	2.5	15	1.1	12	

Air inlet state: 32 °C / 40% r.h., 30 °C / 43% r.h., 28 °C / 47% r.h., 26 °C / 49% r.h., 25 °C / 50% r.h.

¹⁾With this operational data, condensate-free cooling in the operation with circulating air is possible.

5-position switch Positions	Speed min ⁻¹	Sound press. level ¹⁾ dBA	Flow rate in m ³ /h for Δp external total in Pa					
			0 Pa	10 Pa	20 Pa	30 Pa	50 Pa	80 Pa
5	900	51	2100	1900	1650	1500	1300	700
4	700	46	1600	1400	1300	1150	700	
3	600	40	1400	1150	1000	700		
2	500	38	1200	900	500			
1	350	34	800	350				

¹⁾Volume 1500 m³; medium absorption; distance 5m with free suction.

TLHD 40	Heating										Cooling									
Water quantity (l/h)	400 5 6 7 8 9 1000 2000 3000										400 5 6 7 8 9 1000 2000 3000									
Water resistance (kPa)	1 1,5 2 3 4 5 6 7 8 10 12 16										1 1,5 2 3 4 5 6 7 8 10 12 16 20 26									

TopWing Air heater Performance Heating/Cooling TLHD

	Type		TLHD 63							
	Speed		900 min ⁻¹		700 min ⁻¹		500 min ⁻¹		300 min ⁻¹	
	Volume flow		4600 m ³ /h		3600 m ³ /h		2600 m ³ /h		1500 m ³ /h	
		t _{°E} °C	Q kW	t _{LA} °C	Q kW	t _{LA} °C	Q kW	t _{LA} °C	Q kW	t _{LA} °C
Heating	PWW 50/40	5	35.2	27	29.9	29	23.8	31	15.9	35
		10	30.3	29	25.7	31	20.6	33	13.8	37
		15	25.4	31	21.6	33	17.3	35	11.6	38
		20	20.6	33	17.6	35	14.1	36	9.6	39
	PWW 60/50	5	44.9	33	38.0	35	30.2	38	20.0	43
		10	39.9	35	33.8	37	26.9	40	17.8	45
		15	35.0	37	29.7	39	23.6	42	15.7	46
		20	30.1	40	25.6	41	20.4	44	13.6	47
	PWW 70/50	5	47.3	34	40.2	37	32.2	40	21.6	46
		10	42.3	37	36.0	39	28.8	42	19.4	48
		15	37.3	39	31.8	41	25.6	44	17.2	49
		20	32.4	41	27.7	43	22.3	46	15.1	50
	PWW 80/60	5	57.0	40	48.3	43	38.5	47	25.6	54
		10	52.0	43	44.1	46	35.2	49	23.5	55
		15	47.0	45	39.9	48	31.9	51	21.3	57
		20	42.1	47	35.8	50	28.6	53	19.2	58
Cooling	PKW¹⁾ 10/16	32	16.5	21	14.1	21	11.3	20	7.7	18
		30	14.4	20	12.2	20	9.8	19	6.6	17
		28	12.4	20	10.5	19	8.4	18	5.7	17
		26	10.4	19	8.8	19	7.1	18	4.8	16
		25	9.3	19	8.0	18	6.4	18	4.3	16
	Speed		900 min ⁻¹		650 min ⁻¹		400 min ⁻¹		125 min ⁻¹	
	Volume flow		3600 m ³ /h		2600 m ³ /h		1500 m ³ /h		500 m ³ /h	
	PKW 5/10	32	21.3	19	17.1	18	11.7	16	5.0	11
		30	19.3	18	15.6	17	10.6	15	4.6	11
		28	17.4	18	14.0	17	9.6	15	4.2	11
		26	15.3	17	12.3	16	8.4	14	3.7	10
		25	14.2	16	11.5	15	7.8	13	3.4	10
	PKW 6/12	32	19.0	20	15.3	19	10.4	17	4.5	12
		30	17.0	19	13.7	18	9.4	16	4.1	12
		28	15.2	18	12.3	17	8.4	16	3.7	12
		26	13.0	17	10.5	16	7.2	15	3.1	12
		25	11.9	17	9.6	16	6.6	14	2.7	12
	PKW 8/14	32	16.6	20	13.4	19	9.1	17	3.9	14
		30	14.7	19	11.8	18	8.1	17	3.5	13
		28	12.8	19	10.4	18	7.1	16	3.1	13
26		10.6	17	8.6	17	5.9	15	2.2	13	
25		9.6	17	7.7	16	5.3	15	2.0	13	

Air inlet state: 32 °C / 40% r.h., 30 °C / 43% r.h., 28 °C / 47% r.h., 26 °C / 49% r.h., 25 °C / 50% r.h.

¹⁾With this operational data, condensate-free cooling in the operation with circulating air is possible.

5-position switch Positions	Speed min ⁻¹	Sound press. level ¹⁾ dBA	Flow rate in m ³ /h for Δp external total in Pa						
			0 Pa	10 Pa	30 Pa	50 Pa	100 Pa	150 Pa	200 Pa
5	900	55	4600	4300	4000	3700	2800	1800	1000
4	700	49	3600	3300	2600	2300	1300		
3	500	43	2600	2400	1900	1600			
2	450	41	2300	2100	1500	1000			
1	300	37	1500	1350	700				

¹⁾Volume 1500 m³; medium absorption; distance 5m with free suction.

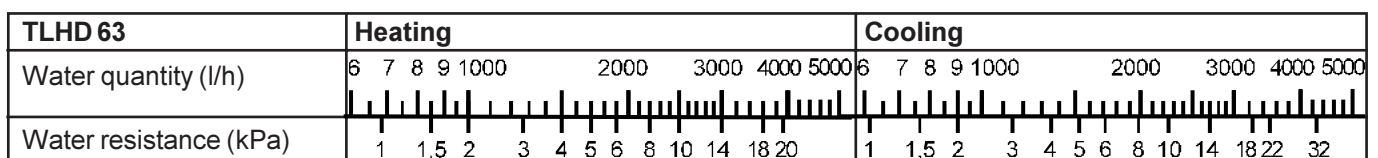

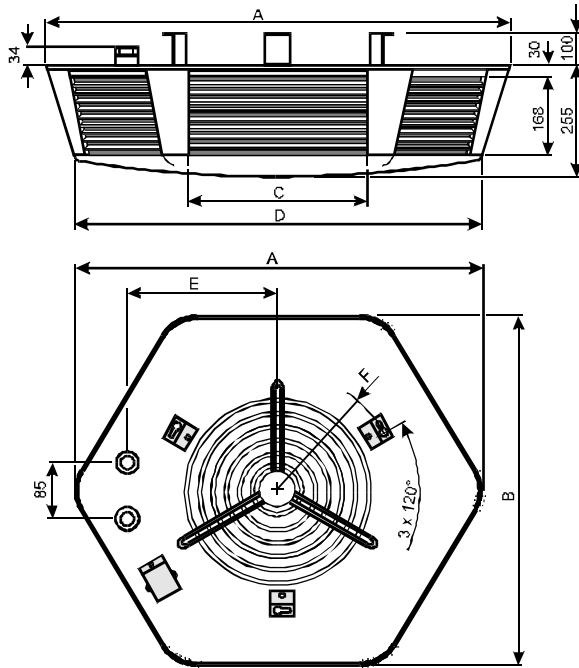

Typ		TLHD 40	TLHD 63
Dimensions	A mm	960	1120
	B mm	860	1000
	C mm	326	405
	D mm	815	975
	E mm	288	358
	F mm	R 317	R 382
Water content	l	3.0	3.6
Connector male thread	R	1"	1"
Weight	kg	47	58
Single-phase motor			
Nominal power	kW	0.13	0.51
Nominal voltage	V	230	230
Nominal current	A	0.55	2.3
Frequency	Hz	50	50
Speed	min ⁻¹	900	900
Degree of protection	IP	54	54
ISO class		F	F
Three phase motor			
Nominal power	kW	0.2 / 0.06	0.2 / 0.06
Nominal voltage	V	3 x 400	3 x 400
Nominal current	A	0.85 / 0.45	0.85 / 0.45
Frequency	Hz	50	50
Speed	min ⁻¹	900	900
Degree of protection	IP	54	54
ISO class		F	F

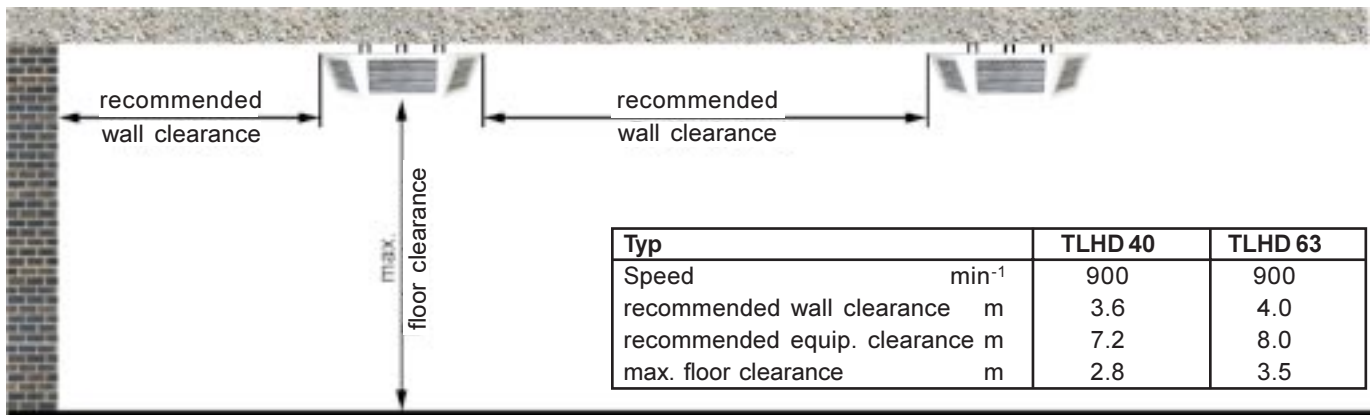

Example for the on-site production of an adjustable supporting device for the installation examples of page 7 to 13.

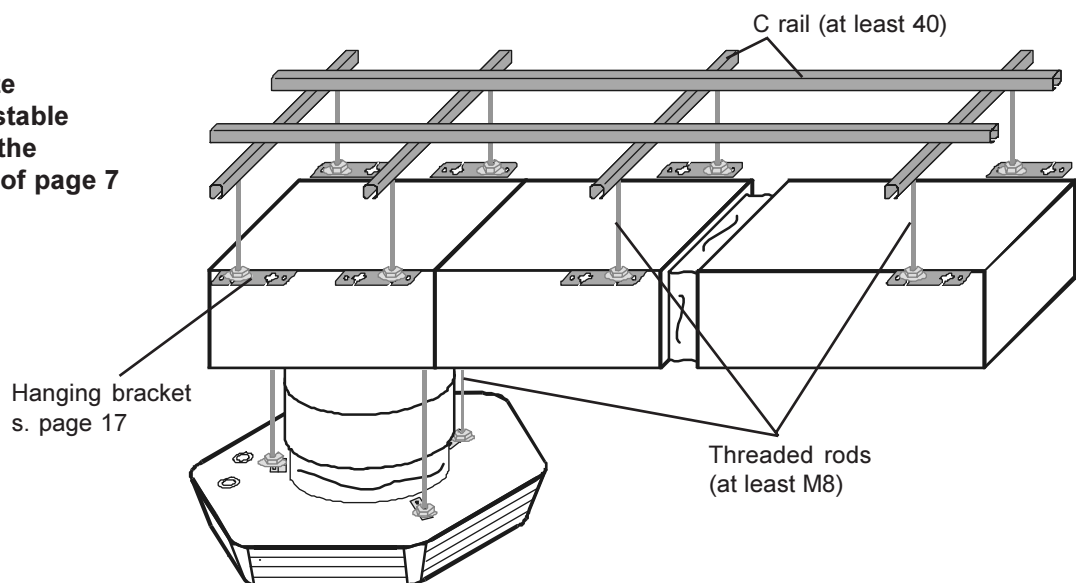

Installation example A:

Operation with circulating air

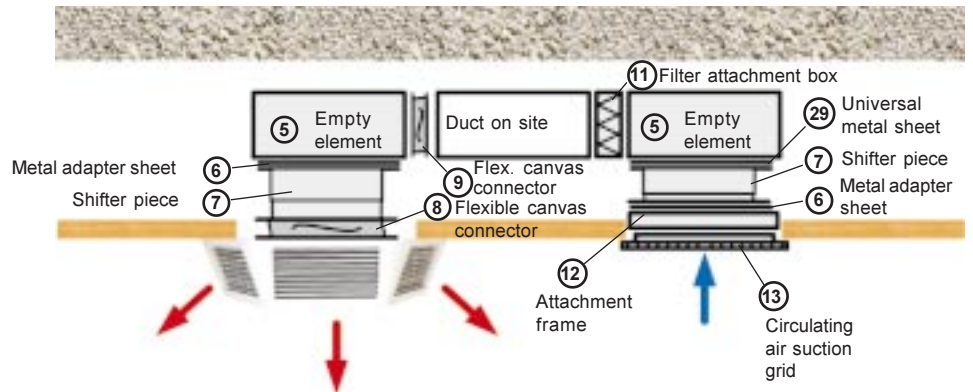

Installation example A, consisting of:

- ⑤ 2 empty elements, panelling double-walled 25 mm, insulated, 2 sides open

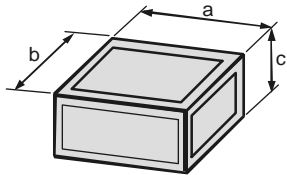

TLHD	a	b	c
40	630	630	300
63	800	800	345

- ⑥ 2 metal adapter sheets, insulated

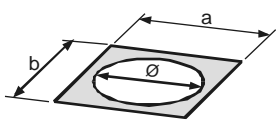

TLHD	a	b	Ø
40	590	590	453
63	760	760	569

- ⑲ Universal metal sheet, as transition from empty element TLHD 63 to accessory shifter piece TLHD 40. The openings must be prepared individually on site, steel sheet, galvanised

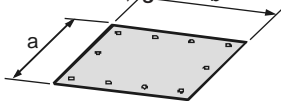

TLHD	a	b
63	760	760

- ⑦ 2 shifter pieces, $l_{\min} = 300$ mm, $l_{\max} = 500$ mm

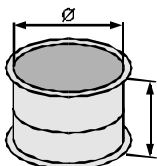

TLHD	Ø
40	453
63	569

- ⑧ Flexible canvas connector

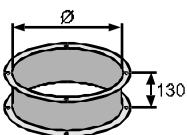

TLHD	Ø
40	453
63	569

- ⑨ Flexible canvas connector

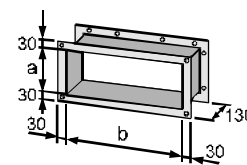

TLHD	a	b
40	200	530
63	245	700

- ⑪ Filter attachment box, with filter grade G4

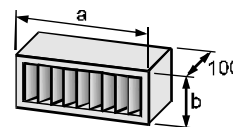

TLHD	a	b
40	630	300
63	800	345

- ⑫ Attachment frame for the connection of empty element and circulating air suction grid

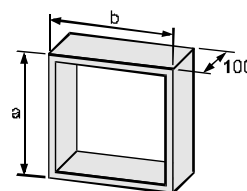

TLHD	a	b
40/63	590	590

- ⑬ Circulating air suction grid, colour white RAL 9016

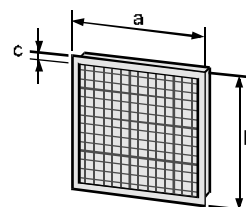

TLHD	a	b	c
40/63	590	590	30

Dimensions in mm

Installation example B:

may be combined with installation examples D, E, F, G

Mixed air operation with air heater TLHD

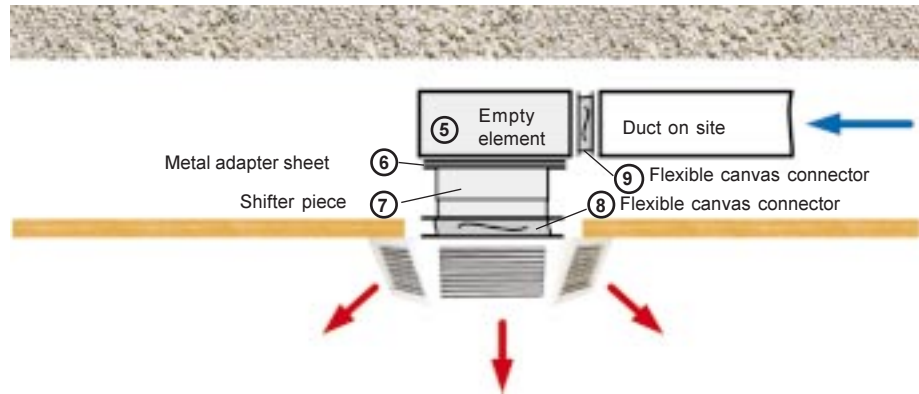

Installation example B, consisting of:

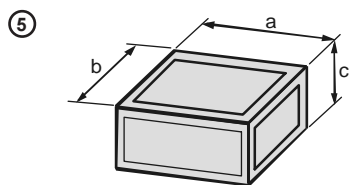

Empty element, panelling double-walled 25 mm, insulated, 2 sides open

TLHD	a	b	c
40	630	630	300
63	800	800	345

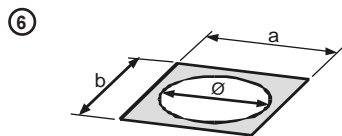

Metal adapter sheet, insulated

TLHD	a	b	Ø
40	590	590	453
63	760	760	569

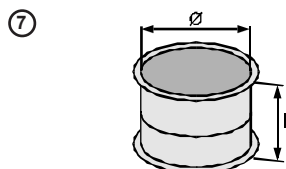

Shifter piece, $l_{min} = 300 \text{ mm}$, $l_{max} = 500 \text{ mm}$

TLHD	Ø
40	453
63	569

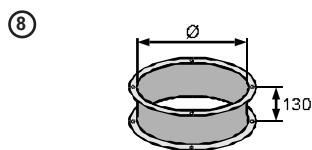

Flexible canvas connector

TLHD	Ø
40	453
63	569

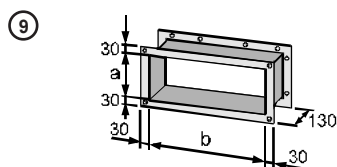

Flexible canvas connector

TLHD	a	b
40	200	530
63	245	700

Dimensions in mm

Note:

With a duct and filter length of 3 m or more, a fan element is recommended (see page 17)

Installation example C:

may be combined with installation examples D, E, F, G

Mixed air operation with air heater TLHD and fan element in flat design as auxiliary fan

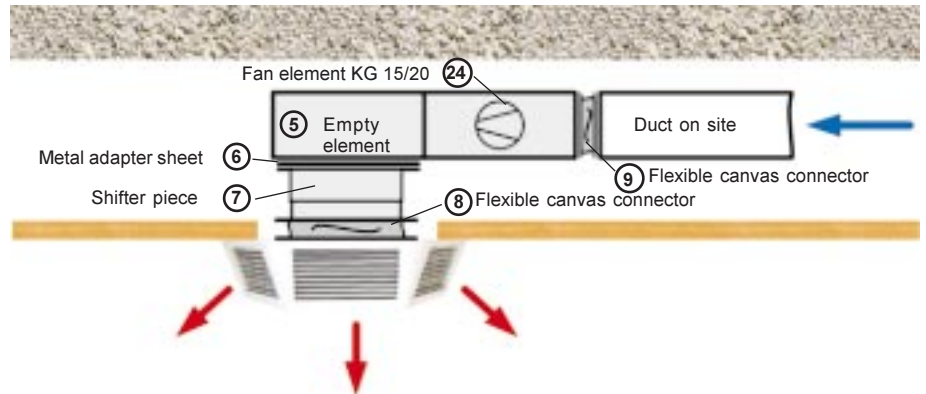

Installation example C, consisting of:

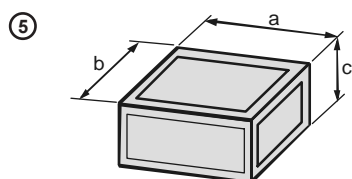

Empty element, panelling double-walled 25 mm, insulated, 2 sides open

TLHD	a	b	c
40	630	630	300
63	800	800	345

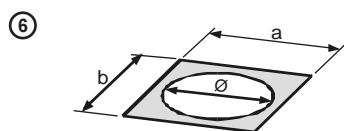

Metal adapter sheet, insulated

TLHD	a	b	Ø
40	590	590	453
63	760	760	569

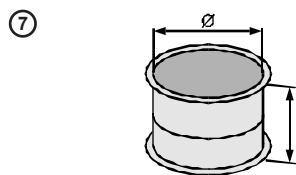

Shifter piece, $l_{\min} = 300$ mm, $l_{\max} = 500$ mm

TLHD	Ø
40	453
63	569

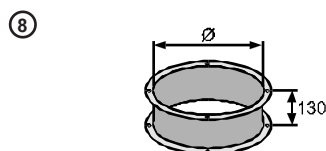

Flexible canvas connector

Type	Ø
TLHD 40	453
TLHD 63	569

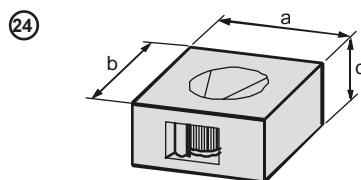

Fan element KG 15 / KG 20 from the series „air conditioners in flat design“ as auxiliary fan. For technical data, see documentation „air conditioners in flat design“. Planning and price by Wolf sales consultants.

TLHD	a	b	c	max. permissible cooling air amount
40	630	630	315	1600 m ³ /h
63	800	800	360	3600 m ³ /h

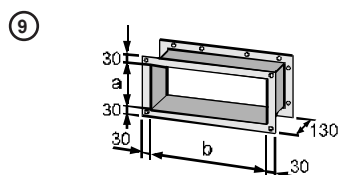

Flexible canvas connector

TLHD	a	b
40	200	530
63	245	700

Dimensions in mm

Installation example D:

Mixed air operation with air heater TLHD

may be combined with installation examples B, C

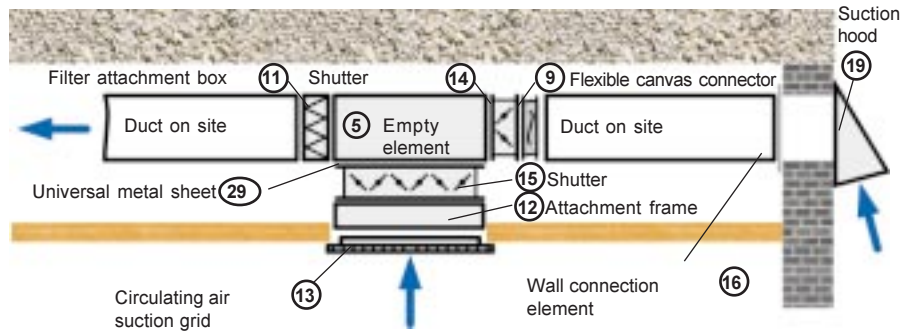

Installation example D, consisting of:

- ⑬ Circulating air suction grid, colour white RAL 9016

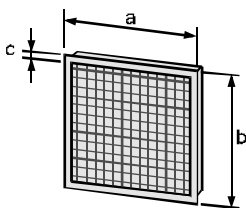

TLHD	a	b	c
40/63	590	590	30

- ⑫ Attachment frame for the connection of shutter and circulating air suction grid

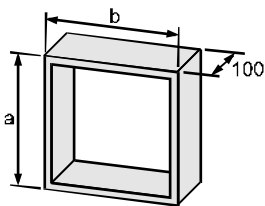

TLHD	a	b
40/63	590	590

- ⑮ Shutter with opposite coupled profile lamellas with plastic connection. Linkage and control lever for manual or motor-supported operation.

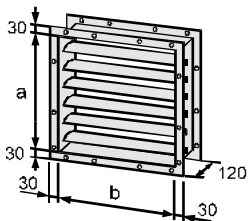

TLHD	a	b
40/63	530	530

- ⑲ Universal metal sheet, as transition from empty element TLHD 63 to accessory shutter TLHD 40. The openings must be prepared individually on site, steel sheet, galvanised

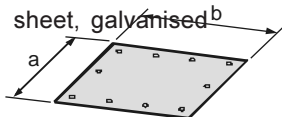

TLHD	a	b
63	760	760

- ⑤ Empty element, panelling double-walled 25 mm, insulated, 3 sides open

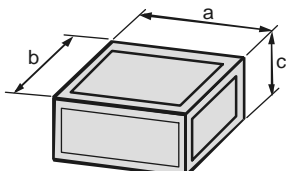

TLHD	a	b	c
40	630	630	300
63	800	800	345

- ⑪ Filter attachment box, with filter grade G4

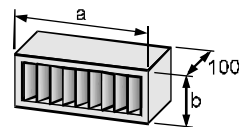

TLHD	a	b
40	630	300
63	800	345

- ⑭ Shutter with opposite coupled profile lamellas with plastic connection. Linkage and control lever for manual or motor-supported operation.

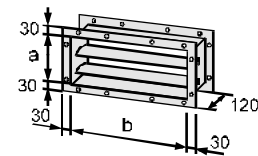

TLHD	a	b
40	200	530
63	245	700

- ⑨ Flexible canvas connector

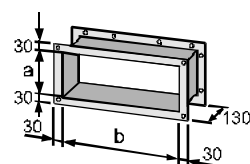

TLHD	a	b
40	200	530
63	245	700

- ⑯ Wall connection element for duct

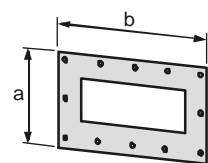

TLHD	a	b
40	460	760
63	460	920

- ⑰ Suction hood with bird safety screen

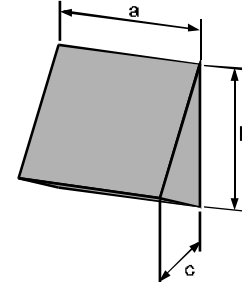

TLHD	a	b	c
40	610	600	420
63	780	770	545

Dimensions in mm

Note:

With a duct and filter length of 3 m or more, a fan element is recommended (see page 17)

Installation example E:

may be combined with installation examples B, C

Mixed air operation with air heater TLHD

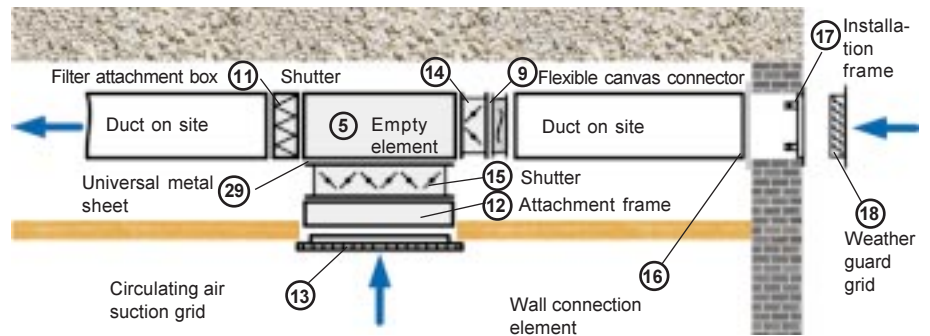

Installation example E, consisting of:

- ⑬ Circulating air suction grid, colour white RAL 9016

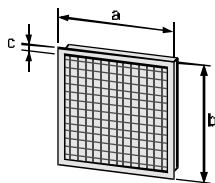

TLHD	a	b	c
40/63	590	590	30

- ⑫ Attachment frame for the connection of shutter and circulating air suction grid

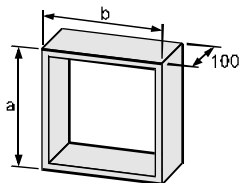

TLHD	a	b
40/63	590	590

- ⑮ Shutter with opposite coupled profile lamellas with plastic connection. Linkage and control lever for manual or motor-supported operation.

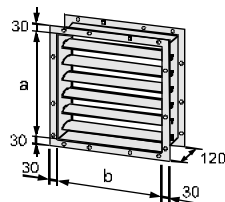

TLHD	a	b
40/63	530	530

- ⑲ Universal metal sheet, as transition from empty element TLHD 63 to accessory shutter TLHD 40. The openings must be prepared individually on site, steel sheet, galvanised

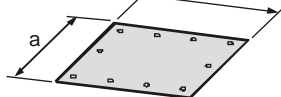

TLHD	a	b
63	760	760

- ⑤ Empty element, panelling double-walled 25 mm, insulated, 3 sides open

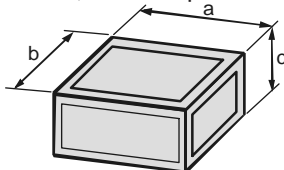

TLHD	a	b	c
40	630	630	300
63	800	800	345

- ⑪ Filter attachment box, with filter grade G4

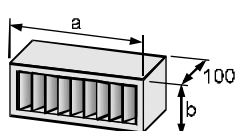

TLHD	a	b
40	630	300
63	800	345

- ⑭ Shutter with opposite coupled profile lamellas with plastic connection. Linkage and control lever for manual or motor-supported operation.

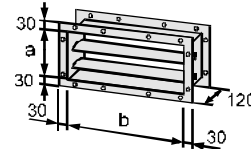

TLHD	a	b
40	200	530
63	245	700

- ⑨ Flexible canvas connector

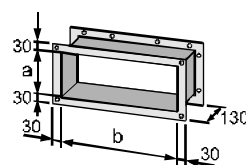

TLHD	a	b
40	200	530
63	245	700

- ⑯ Wall connection element for duct

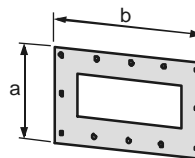

TLHD	a	b
40	460	760
63	460	920

- ⑰ Installation frame for weather guard grids

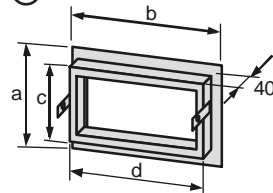

TLHD	a	b	c	d
40	294	624	234	564
63	339	794	279	734

Note: no load-carrying capacity, provide lintel if necessary, plan wall cut-out 5 mm larger all around.

- ⑱ Weather guard grid

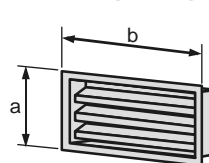

TLHD	a	b
40	290	620
63	335	790

Dimensions in mm

Note:

With a duct and filter length of 3 m or more, a fan element is recommended (see page 17)

Installation example F:

may be combined with installation examples B, C

Mixed air operation with air heater TLHD

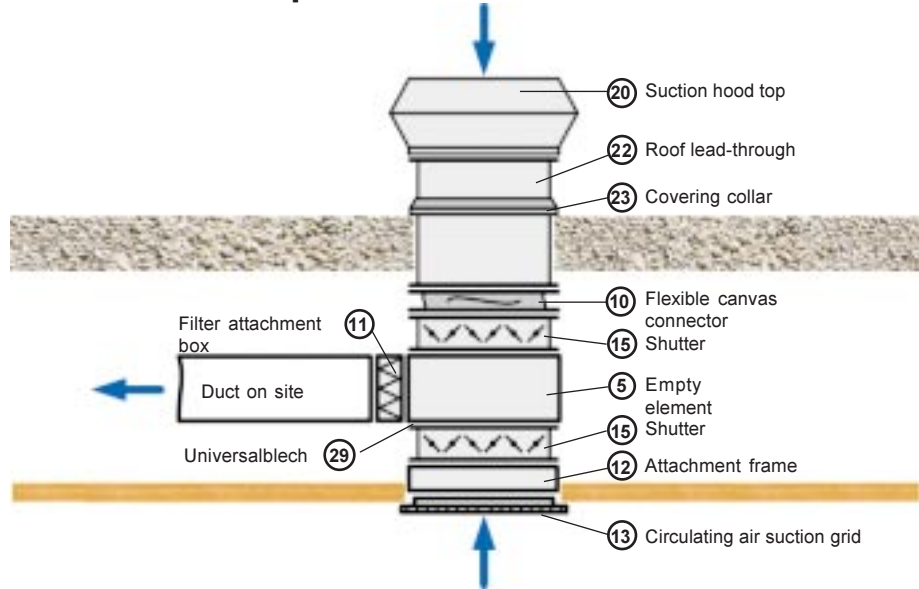

Installation example F, consisting of:

20 Suction hood top

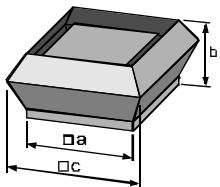

TLHD	a	b	c
40	710	524	995
63	900	630	1247

22 Roof lead-through

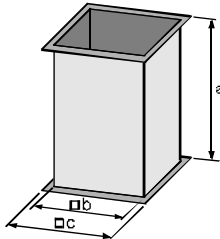

TLHD	a	b	c
40	1100	630	730
63	1100	800	900

23 Covering collar for roof lead-through

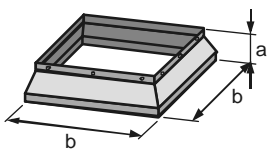

TLHD	a	b
40	180	710
63	180	880

10 Flexible canvas connector

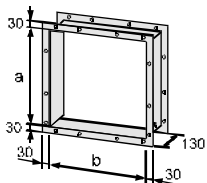

TLHD	a	b
40	530	530
63	700	700

5 Empty element, panelling double-walled 25 mm, insulated, 3 sides open

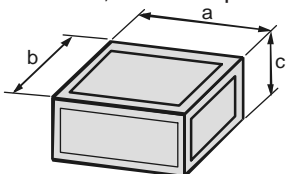

TLHD	a	b	c
40	630	630	300
63	800	800	345

29 Universal metal sheet, as transition from empty element TLHD 63 to accessory shutter TLHD 40. The openings must be prepared individually on site, steel sheet, galvanised

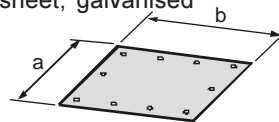

TLHD	a	b
63	760	760

15 2 shutters with opposite coupled profile lamellas with plastic connection. Linkage and control lever for manual or motor-supported operation.

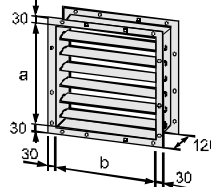

TLHD	a	b
40	530	530
63	700	700

12 Attachment frame for the connection of shutter and circulating air suction grid

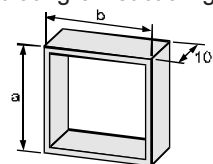

TLHD	a	b
40/63	590	590

13 Circulating air suction grid, colour white RAL 9016

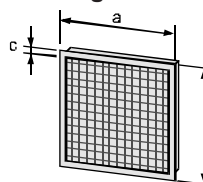

TLHD	a	b	c
40/63	590	590	30

11 Filter attachment box, with filter grade G4

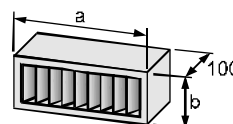

TLHD	a	b
40	630	300
63	800	345

Dimensions in mm

Note: With a duct and filter length of 3 m or more, a fan element is recommended (see page 17)

Installation example G:

may be combined with installation examples B, C

Mixed air operation with air heater TLHD

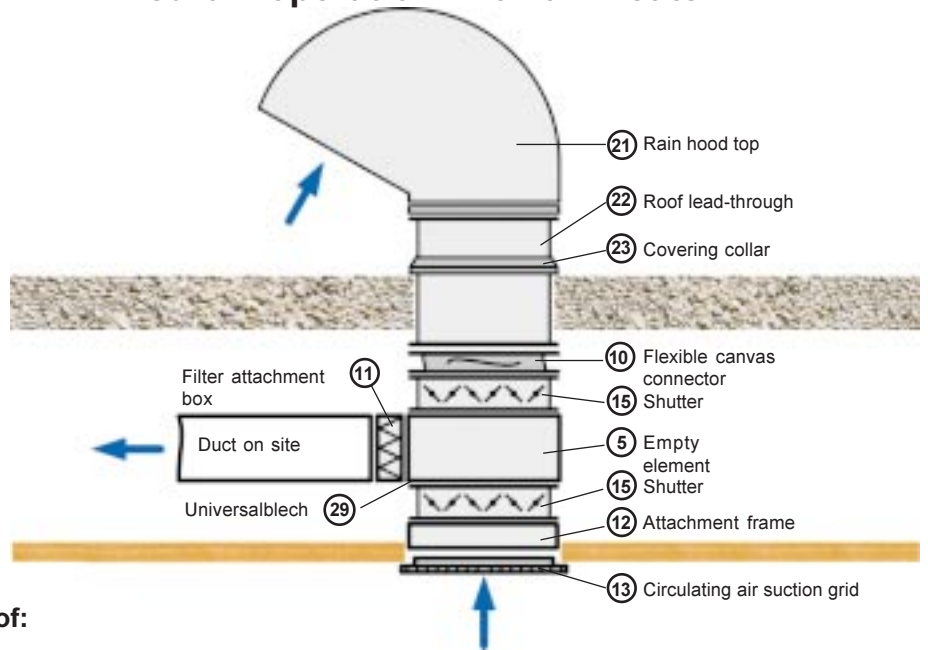

Installation example G, consisting of:

21 Rain hood top

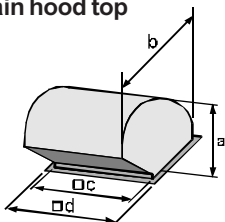

TLHD	a	b	c	d
40	770	1254	630	736
63	940	1570	800	906

22 Roof lead-through

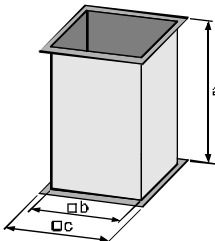

TLHD	a	b	c
40	1100	630	730
63	1100	800	900

23 Covering collar for roof lead-through

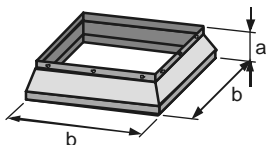

TLHD	a	b
40	180	710
63	180	880

10 Flexible canvas connector

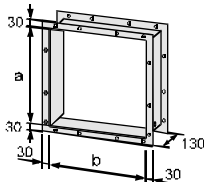

TLHD	a	b
40	530	530
63	700	700

5 Empty element, panelling double-walled 25 mm, insulated, 3 sides open

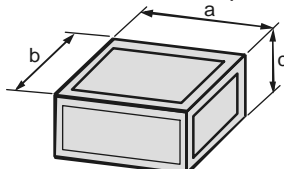

TLHD	a	b	c
40	630	630	300
63	800	800	345

29 Universal metal sheet, as transition from empty element TLHD 63 to accessory shutter TLHD 40. The openings must be prepared individually on site, steel sheet, galvanised

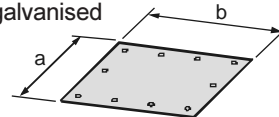

TLHD	a	b
63	760	760

15 2 shutters with opposite coupled profile lamellas with plastic connection. Linkage and control lever for manual or motor-supported operation.

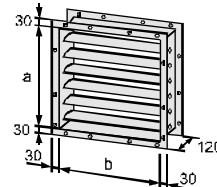

TLHD	a	b
40	530	530
63	700	700

12 Attachment frame for the connection of shutter and circulating air suction grid

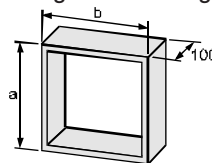

TLHD	a	b
40/63	590	590

13 Circulating air suction grid, colour white RAL 9016

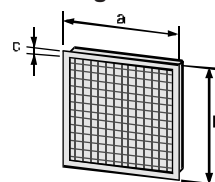

TLHD	a	b	c
40/63	590	590	30

11 Filter attachment box, with filter grade G4

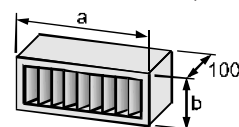

TLHD	a	b
40	630	300
63	800	345

Dimensions in mm

Note:

With a duct and filter length of 3 m or more, a fan element is recommended (see page 17)

① Shut-off sets for heat exchanger

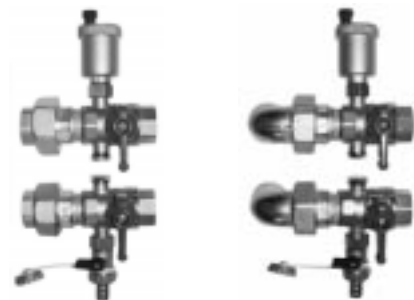

Passage design
Art. no. 20 08 030

Corner design
Art. no. 20 08 040

Shut-off set in passage design or corner design for supply and return of the heat exchanger for TLHD, consisting of:

Connector 1" for connection to supply and return

automatic venting valve in supply

Fill and emptying cock in return

Ball valves with female thread 1" in supply and return

Connection type 1/2" female threads (e.g. for thermometers) in supply and return

② Siphon

As water trap and condensate drain, for TLHD with cooling



TLHD	Art. no.
40	20 11 005
63	20 11 005

③ Top filter

for TLHD, grade G1, with attachment clips, not suitable for duct connection.

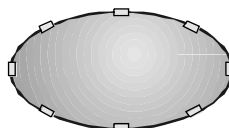

TLHD	Art. no.
40	65 11 530
63	65 11 531

④ Suction ring

for TLHD for the lining of the intake air gap when assembling directly to the ceiling or as decorative cover in all installation examples;
white RAL 9016

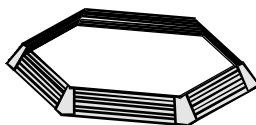

TLHD	Art. no.
40	65 11 553
63	65 11 554

⑤ Empty element

Panelling double-walled 25 mm, insulated
Steel sheet, galvanised.

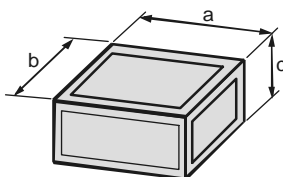

TLHD	a	b	c	Art. no.
40	630	630	300	65 11 577
63	800	800	345	65 11 578

⑥ Metal adapter sheet

for the connection of round shifter piece with empty element or attachment frames, insulated
Steel sheet, galvanised.

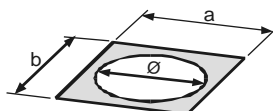

TLHD	a	b	Ø	Art. no.
40	590	590	453	65 11 587
63	760	760	569	65 11 588

⑦ Shifter piece

for compensation of different dimensions
 $l_{min} = 300 \text{ mm}$, $l_{max} = 500 \text{ mm}$
Steel sheet, galvanised.

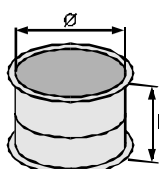

TLHD	Ø	Art. no.
40	453	25 26 040
63	569	25 26 063

TopWing Air heater

Accessories TLHD

- ⑧ Flexible canvas connector
for connection to TLHD

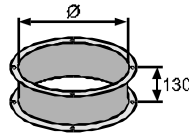

TLHD	Ø	Art. no.	
40	453	65 11 535	
63	569	65 11 537	

- ⑨ Flexible canvas connector
for connection to duct

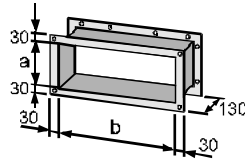

TLHD	a	b	Art. no.	
40	200	530	25 24 015	
63	245	700	25 24 020	

- ⑩ Flexible canvas connector
for connection to roof lead-through

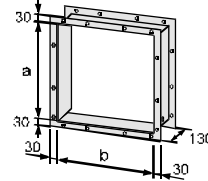

TLHD	a	b	Art. no.	
40	530	530	25 25 040	
63	700	700	25 25 063	

- ⑪ Filter attachment box
with filter grade G4

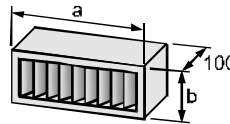

TLHD	a	b	Art. no.	
40	630	300	61 05 100	
63	800	345	61 05 101	

- ⑫ Attachment frame insulated
for connection of shutter/metal adapter
sheet and circulating air suction grid
Steel sheet, galvanised.

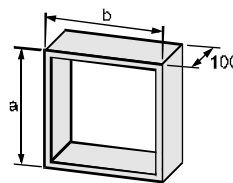

TLHD	a	b	Art. no.	
40/63	590	590	61 11 595	

- ⑬ Circulating air suction grid
for the installation into the attachment frame
white RAL 9016

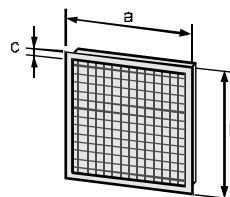

TLHD	a	b	c	Art. no.
40/63	590	590	30	25 65 525

- ⑭ Shutter
for duct
Steel sheet, galvanised.

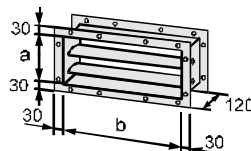

TLHD	a	b	Art. no.	
40	200	530	60 06 000	
63	245	700	60 06 001	

- ⑮ Shutter
for roof lead-through and attachment frame/
circulating air suction grid
Steel sheet, galvanised.

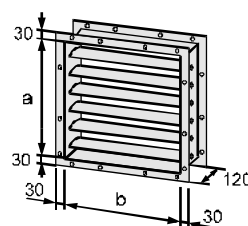

TLHD	a	b	Art. no.	
40	530	530	60 22 702	
63	700	700	60 32 703	

TopWing Air heater

Accessories TLHD

- ①⑥ **Wall connection element**
for duct
Steel sheet, galvanised.

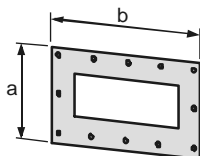

TLHD	a	b	Art. no.
40	460	760	65 11 589
63	460	920	65 11 590

- ①⑦ **Installation frame**
for weather guard grids
Steel sheet, galvanised.

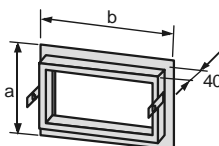

TLHD	a	b	Art. no.
40	224	624	25 65 407
63	339	794	25 65 408

- ①⑧ **Weather guard grid**
Steel sheet, galvanised.

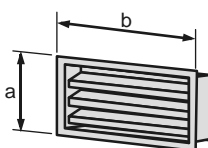

TLHD	a	b	Art. no.
40	290	620	25 65 405
63	335	790	25 65 406

- ①⑨ **Suction hood wall**
Steel sheet, galvanised.

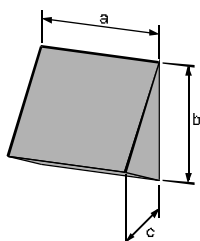

TLHD	a	b	c	Art. no.
40	610	600	420	60 22 952
63	780	770	545	60 32 953

- ①⑩ **Suction hood top**
for roof lead-through
Steel sheet, galvanised.

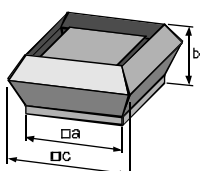

TLHD	a	b	c	Art. no.
40	610	600	420	21 00 204
63	780	770	545	21 00 205

- ①⑪ **Rain hood with bird safety screen**
Steel sheet, galvanised.

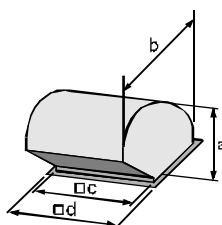

TLHD	a	b	c	d	Art. no.
40	770	1254	630	736	25 51 040
63	940	1570	800	906	25 51 063

- ①⑫ **Roof lead-through**
1100mm long
Steel sheet, galvanised.

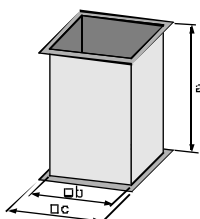

TLHD	a	b	c	Art. no.
40	1100	630	730	25 50 040
63	1100	800	900	25 50 063

TopWing Air heater

Accessories TLHD

- 23 Covering collar**
for roof lead-through
Steel sheet, galvanised.

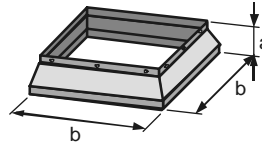

TLHD	a	b	Art. no.
40	180	710	65 13 482
63	180	880	65 13 483

- 24 Fan element**
Fan element KG15/20 from series „air conditioners in flat design“ as: auxiliary fan

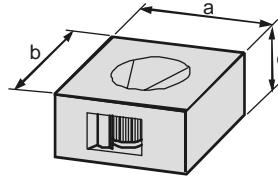

TLHD	a	b	c	Art. no.
40	630	630	315	65 11 585
63	800	800	360	65 11 586

Planning and price by Wolf sales consultants

Max. permissible cooling air amount:

TLHD 40: 1600 m³/h

TLHD 63: 3600 m³/h

- 25 Ceiling exhaust TD**
Housing such as TLHD, without heat exchangers, without fan motor unit, as ceiling exhaust.
Dimensions same as TLHD
white RAL 9016

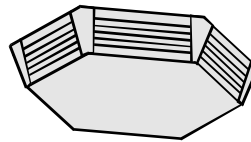

TLHD	Art. no.
40	65 11 549
63	65 11 550

- 26 Differential pressure monitor**
For filter monitoring



TLHD	Art. no.
40	27 38 360
63	27 38 360

- 27 Hanging bracket**
For mounting of fan element / supply air device and empty elements, directly on ceiling
Stahlblech, verzinkt



TLHD	Art. no.
40	65 011 454
63	65 011 454

- 28 Universal panelling metal sheet, front side**
as transition from empty element / fan element to duct on site. The openings must be prepared individually on site. Steel sheet, galvanised.

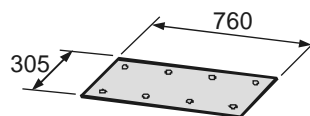

TLHD	Art. no.
40	60 13 102
63	60 01 131

- 29 Universal panelling metal sheet, square**
as transition from empty element TLHD 63 to accessory shutter / shifter piece TLHD 40. The openings must be prepared individually on site, steel sheet, galvanised.

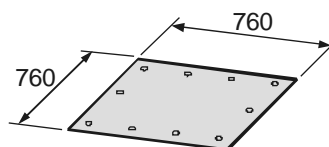

TLHD	Art. no.
63	60 11 123

TopWing Air heater Switching and Control devices TLHD



Three phase motor
3 x 400 V



Single phase motor
230 V

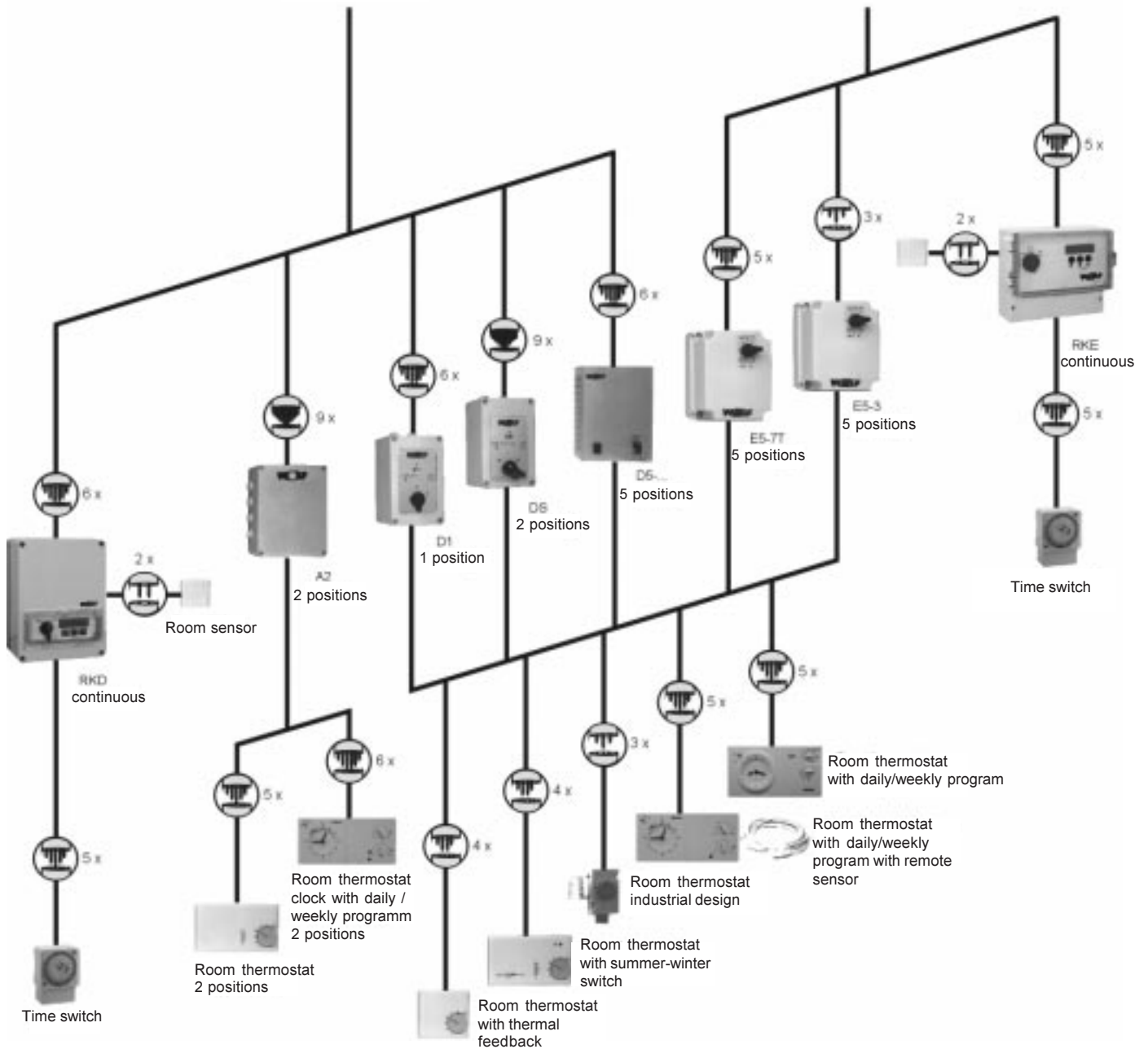



RKE with room temperature sensor:

Automatic, continuous speed adaptation of the fan depending on room temperature, for single-phase motors 230 V / 50/60 Hertz / 6A, suitable for heating and air conditioning.

LED display with 5 digits for

- Day / night temperature
- min. speed
- max. speed
- Sensor alignment
- Proportional band setting
- Reversal of direction of action heating / cooling
- Alarm for high and/or low room temperature
- Motor malfunction

Menu-assisted setting via 3 function keys

- Day / night set point setting (timer required)
- Switch heating / cooling



Full motor protection (by thermal contacts in the motor)

-Semiconductor- type fuse

Potential-free operation reporting contact

Alarm function for high or low temperature

Main switch with bypass function

RKD with room temperature sensor:

Automatic, continuous speed adaptation of the fan depending on room temperature as before but for three phase motors 3 x 400 V 50/60 Hertz / 8A.



Accessories:

Timer with weekly program for set-back operation.

Switching devices	D1	DS	D5-1	D5-3	D5-7	D5-12	A2	E5-3	E5-7T	RKE	RKD
Article number	7940001	7925110	2740015	2740010	2740013	2740014	7925130	2740006	2740011	2741066	2741065
Operating voltage	V 3 x 400	3 x 400	3 x 400	3 x 400	3 x 400	3 x 400	3 x 400	230	230	230	3 x 400
Control voltage	V 230	230	230	230	230	230	230	230	230	230	-
Power max.	kW 3	4	-	-	-	-	4	-	-	-	-
Current max.	A -	-	1.0	2.0	4.0	7.0	-	3.0	7.0	6.0	8.0
Degree of protection	IP 54	54	40	20	20	20	55	40	40	54	54
Length	mm 170	170	200	310	310	310	220	200	200	231	190
Width	mm 105	105	150	230	230	230	170	150	150	185	255
Height	mm 135	135	175	185	185	185	110	175	175	113	140
Weight	kg 0.9	0.9	4.5	7.0	9.0	19.0	2.0	4.0	5.0	2.0	6.0

1-position switch D1

for single-speed operation of one or more air heaters with full motor protection.

Operating voltage	400 V
Control voltage	230 V
Power max.	3 kW
Weight	0.9 kg
Degree of protection	IP 54

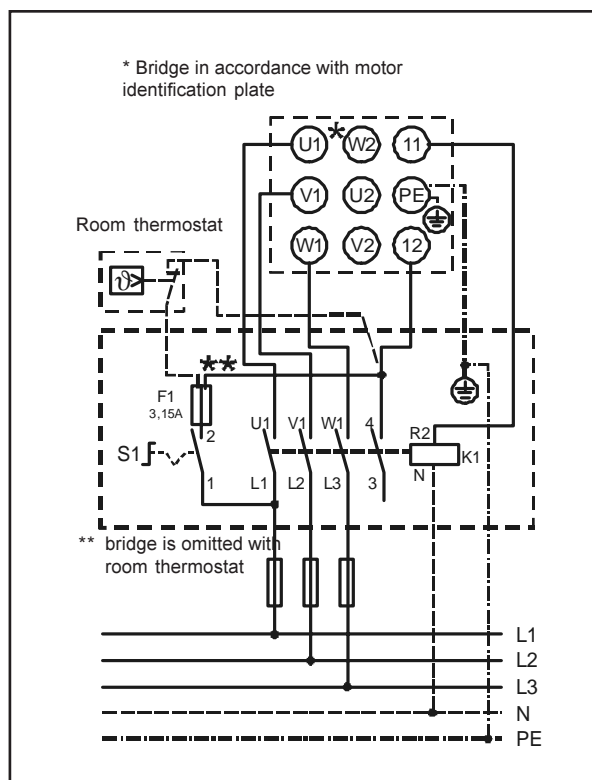

2-position switch DS

for two-speed operation of one or more air heaters with full motor protection.

Operating voltage	400 V
Control voltage	230 V
Power max.	4 kW
Weight	0.9 kg
Degree of protection	IP 54

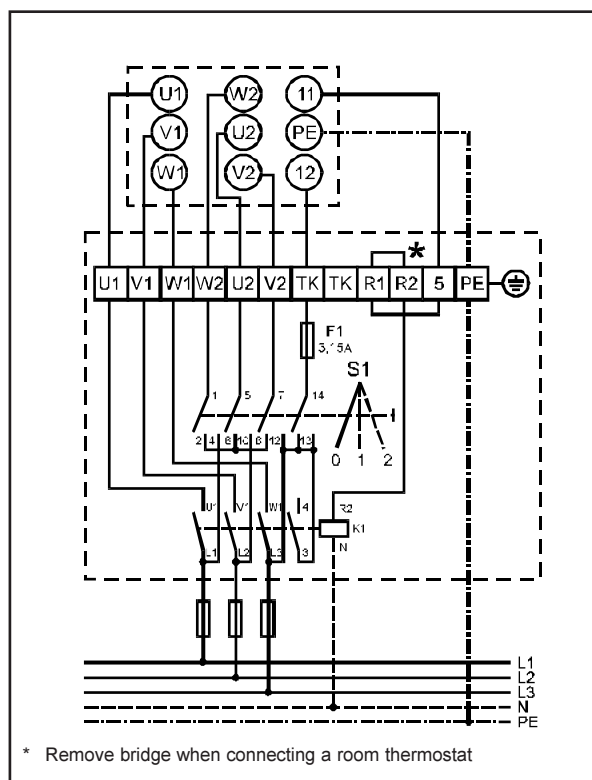

Note:

Without switching devices for full motor protection, no motor guarantee! Installation in accordance with the local power supply companies regulations.

Full motor protection switch for 3 x 230 V on request.

5-position switch D 5-...

for 5-speed operation of one or more air heaters with full motor protection.

Type	D5-1	D5-3	D5-7	D5-12
Operating voltage V	400	400	400	400
Control voltage kW	230	230	230	230
Current max.A	1	2	4	7
Weight kg	4.5	7.0	9.0	19.0
Prot. class IP	40	20	20	20

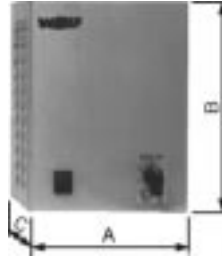

Dimensions

Type	D5-1	D5-3	D5-7	D5-12
Width A	150	230	230	230
Height B	200	310	310	310
Depth C	175	185	185	181

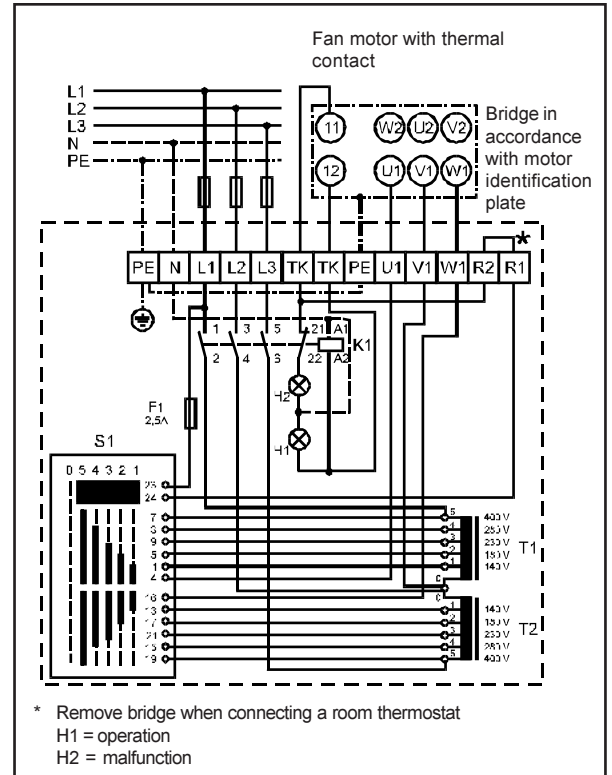

5-position switch E 5-3

for 5-speed operation of one or more air heaters with single-phase motors with full motor protection.

Operating voltage	230 V
Current max.	3 A
Weight	4.0 kg
Protection class	IP 40

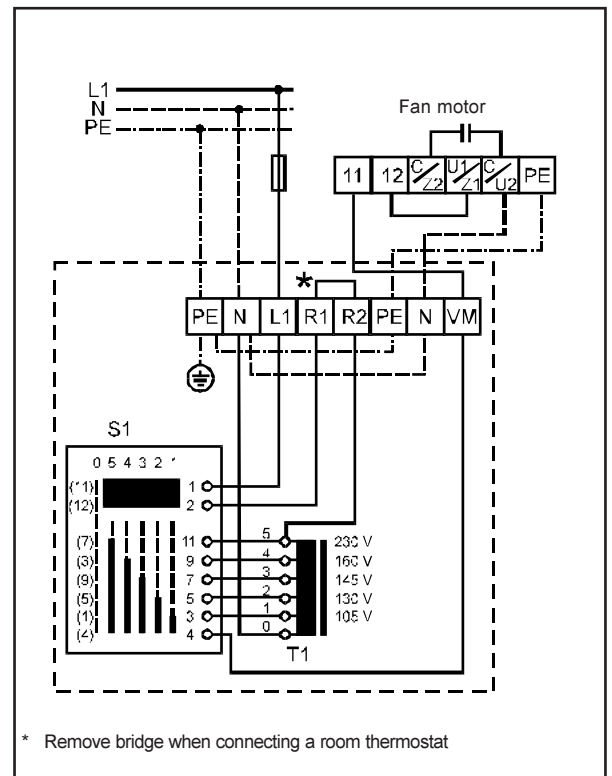

Note:

Without switching devices for full motor protection, no motor guarantee!
Installation in accordance with the local power supply companies regulations.

Full motor protection switch for 3 x 230 V on request.

TopWing Air heater Controllers for mixed air operation

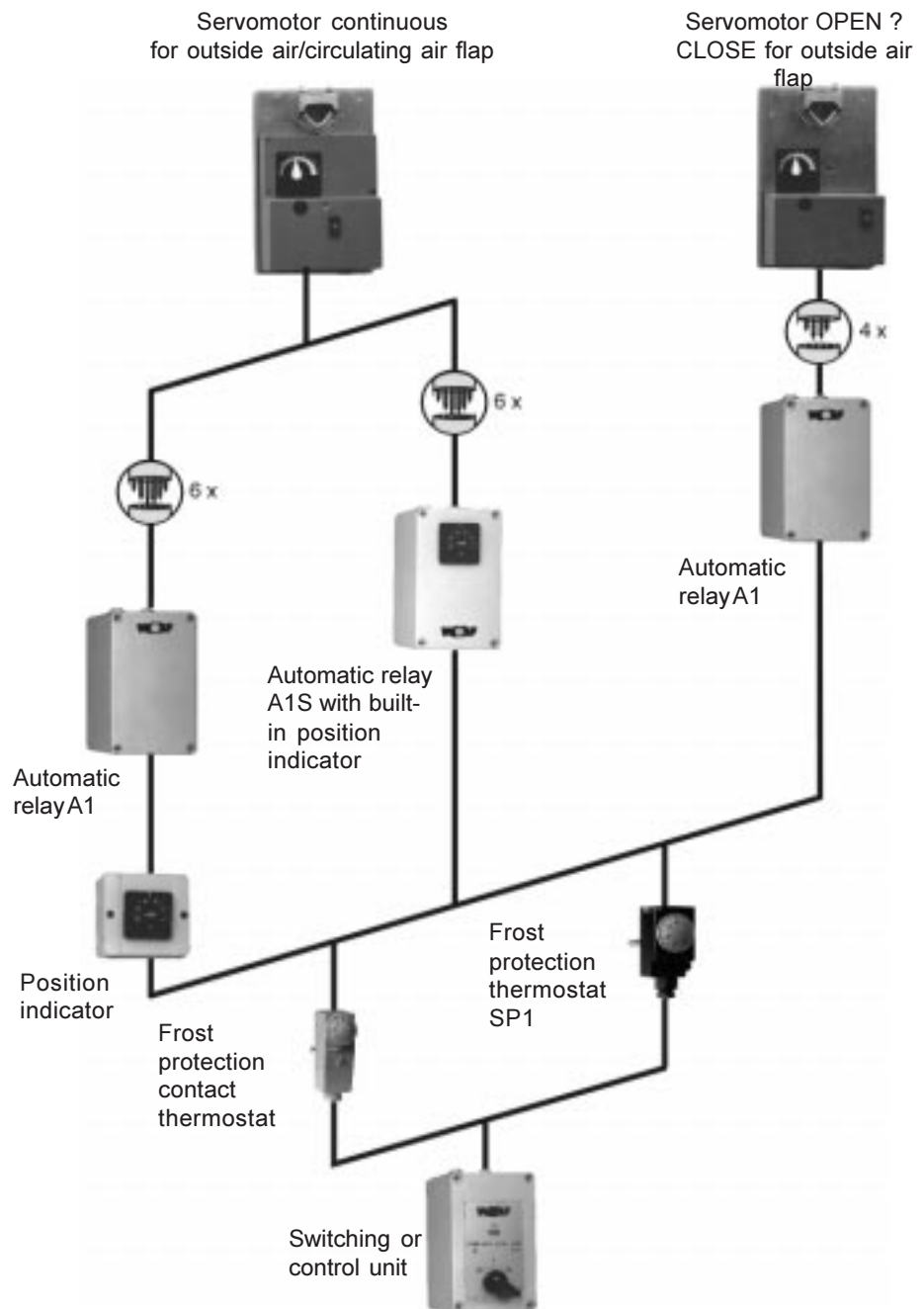

Servomotor OPEN - CLOSED 230 V For automatic operation of an outside air flap in connection with the automatic relay A1.

- | | | |
|--------------------------------------|---|-------------------------|
| Start-up of the TLHD | → | outside air flap opens |
| Shut-down of the TLHD | → | outside air flap closes |
| Supply thermostat SP-1 responds or | → | outside air flap closes |
| Supply temp. contact sensor responds | → | outside air flap closes |

Servomotor continuous 230 V

For the automatic, continuous control of the outside air/circulating air flaps in connection with the automatic relay A1 and a position indicator in the switching cabinet or in surface-mounted installation, or with the automatic relay A1S with an integrated position indicator.

- | | | |
|---|---|---|
| Start-up of the TLHD | → | Outside air flap opens to the set value, the circulating air flap closes accordingly. |
| Shut-down of the TLHD | → | Outside air flap closes; the circulating air flap is opened 100%. |
| Frost prot. thermostat SP-1 responds | → | Outside air flap closes; the circulating air flap is opened 100%. |
| Frost prot. contact thermostat responds | → | Outside air flap closes; the circulating air flap is opened 100%. |

TopWing Air heater Controllers for mixed air operation

Automatic relay A1

Auxiliary relay for the automatic control of the outside air flap with servomotor 230 V „Open - Closed“.

The automatic relay A1 sets the servomotor on position „Closed“ when switching off the device or when the frost protection thermostats (temperature guard) responds; when switching on the device, the servomotor switches to the position „Open“.

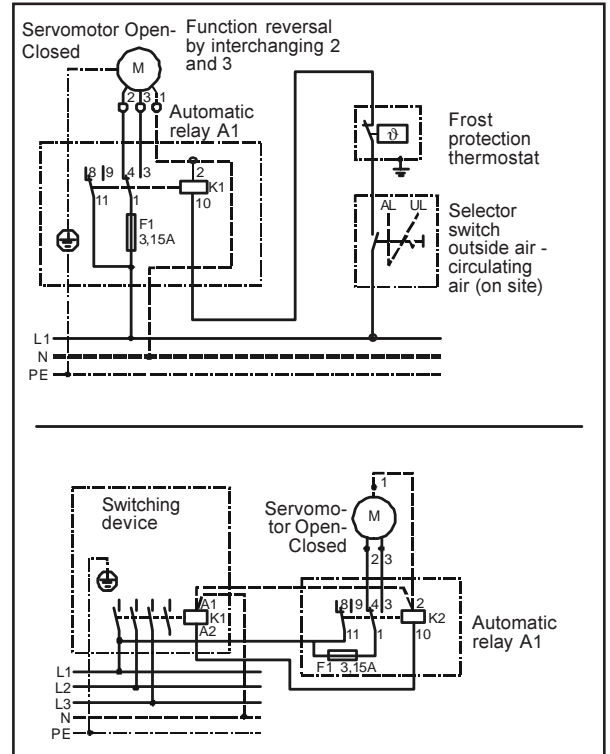

Automatic relay A1S

Auxiliary relay with built-in position indicator for automatic control of the outside air/circulating air flaps with linear motor 230 V, continuous. The automatic relay A1S sets the servomotor on position „Closed“ when switching off the device or when the frost protection thermostats (temperature guard) responds; when switching on the device, the servomotor switches to the value set in the position indicator (0 - 100%).

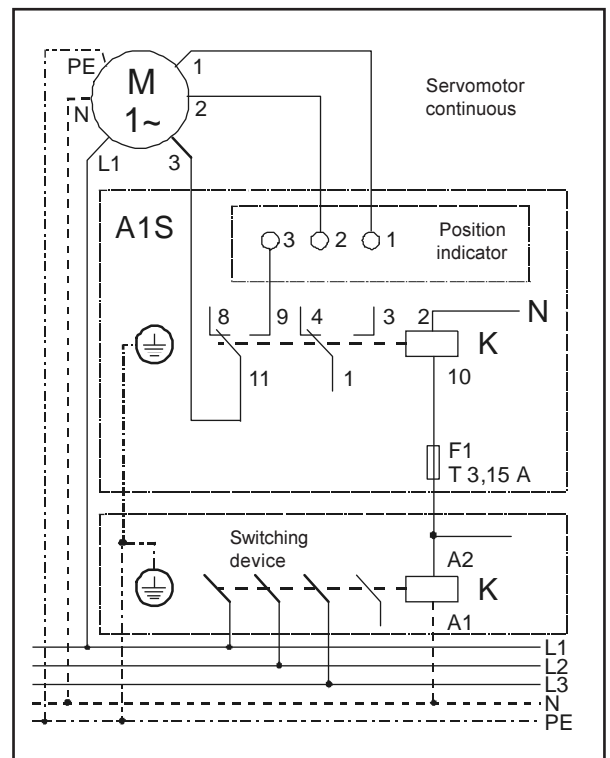
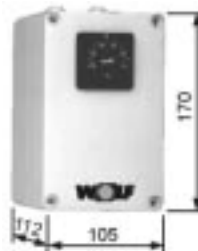

Control units	Servomotor continuous	Servomotor Open-Closed	Automatic relay A1	Automatic relay A1S	Position indicator	Frost guard	
						Frost prot. therm. with imm. sl. SP-1	Frost prot.cont. thermostat
Art. no.	22 36 550	22 36 600	79 65 020	79 65 012	79 65 022	27 97 005	27 91 905
Operating voltage	V 230	230	230	230	9	Alternating contact	Alternating contact
Control voltage	V 1.5-7.5	230	230	230	1.5-7.5	250/10(2.5)A	250/15(2.5A)
Power max.	kW 4.5	1.8	1	1	0.1		
Current max.	5VA	4VA	3.15V	3.15V	0.1VA		
Protection class	P 42	42	54	54	54	20	20
Length	mm 196	196	170	170	48	44/164	120
Width	mm 123	123	105	105	48	46	38
Height	mm 65	69	112	112	33	92	20
Weight	kg 1.55	1.4	0.5	0.5	0.015	0.2	0.15

TopWing Air heater Power depending on accessories TLHD

Symbol	\dot{V}	= Volume flow	m ³ /h
	\dot{V}_B	= reference volume flow	m ³ /h
	\dot{V}_O	= catalogue volume flow	m ³ /h
Conversion:	\dot{V}_{eff}	= effective volume flow	m ³ /h
1 Pa = 0.1 mm WC	t_{Le}	= air entry temperature	°C
1 kPa = 1000 Pa	t_{LA}	= air outlet temperature	°C
	$t_{LA\ eff}$	= effective air outlet temperature	°C
	Δt_L	= air temperature rise	K
	Δt_W	= temp. spreading of the water	K
	W	= water quantity	m ³ /h
	\dot{Q}	= thermal output	kW
	\dot{Q}_O	= catalogue thermal output	kW
	\dot{Q}_{eff}	= effective thermal output	kW
	Δp	= air resistance	Pa
	Δp_W	= Water resistance	kPa
	e	= heating factor	
	q_{eff}	= heating power factor	
	l_{eff}	= air volume factor	
	K	= acc. index of the complete device	

Design example TLHD

Given:

Kit A: Operation with circulating air
TLHD 63, $t_{LE} = 20^\circ\text{C}$, PWW 70/50

To be calculated:

Effective air volume \dot{V}_{eff}
Effective heating power \dot{Q}_{eff}
Effective air outlet temp. $t_{LA\ eff}$

at $n = 900\ \text{min}^{-1}$

Accessories index k: ($k = 1 \hat{=} 10\text{Pa at } \dot{V}_B$)

Metal adapter sheet	3
Att. frame for circ. air suction grids	0
Suction hood top	5
Suction hood wall	3
Roof lead-through	0
Top exhaust TD without register	2
Installation frame weather guard grids	0
Filter attachment box with filter G4	5
Shutter „Q“	1
Shutter „S“	3
Empty element	0.5
Empty element with 90° deflection	3
Rain hood top	2
Shifter piece round	0
Flexible canvas connector „Q“	0
Flexible canvas connector „S“	0
Flexible canvas connector round	0
Circulating air suction grid TLHD 40	1
Circulating air suction grid TLHD 63	4
Universal metal sheet transition 63/40	3
Wall connection element	0
Weather guard grid	7

For on-site accessories, k must be calculated:

$$k = 0.1 \cdot \Delta p \cdot \left(\frac{\dot{V}_B}{\dot{V}}\right)^2$$

Δp = air resistance (Pa) at \dot{V} (m³/h)
 \dot{V} = volume flow (m³/h) at Δp (Pa)

TLHD	\dot{V}_B
40	2000 m ³ /h
63	4000 m ³ /h

Characteristic diagram

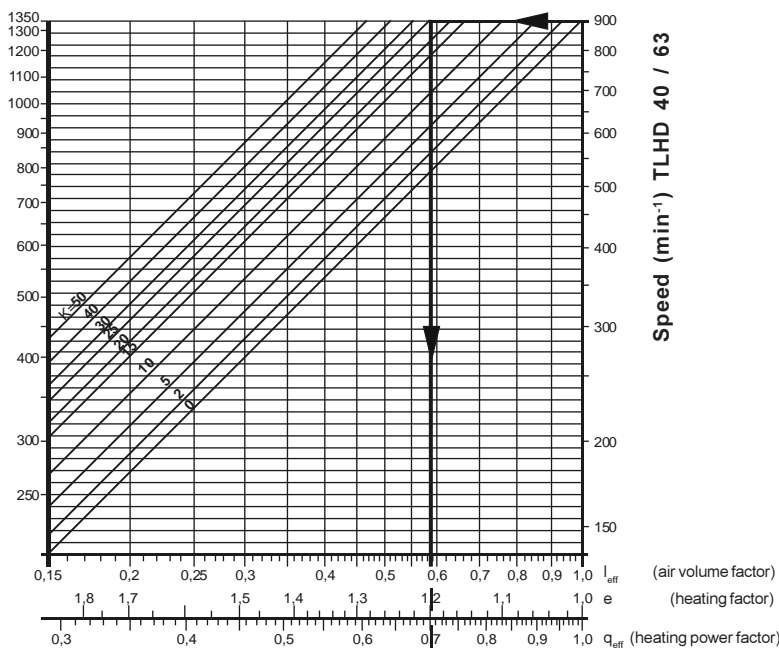

Solution:

Read pressure drops of all accessories (index K) from table.

- Empty el. with 90° def. $k = 3 \times 2 = 6.0$
- Metal adapter sheet $k = 3 \times 2 = 6.0$
- Shifter piece $k = 0 \times 2 = 0.0$
- Flex. canvas con. round $k = 0 \times 1 = 0.0$
- Flex. canvas connect. „S“ $k = 0 \times 1 = 0.0$
- Filter box with filter G4 $k = 5 \times 1 = 5.0$
- Circul. air suction grid $k = 4 \times 1 = 4.0$
- Attachment frame $k = 0 \times 1 = 0.0$
- Empty element $k = 0.5 \times 1 = 0.5$
- Univ. metal sheet trans. $k = 3 \times 1 = 3.0$

$$\Sigma k = 24.5 \times 10 = 245\ \text{Pa}$$

Reading from entry in characteristic diagram:

$$l_{eff} = 0.59 \quad e = 1.20 \quad q_{eff} = 0.70$$

Always read performance data from performance table at upper speed 900 min⁻¹.

$$\dot{V} = 4600\ \text{m}^3/\text{h}, \quad \dot{Q} = 32.4\ \text{kW}$$

$$t_{LA} = 41^\circ\text{C}$$

$$\dot{V}_{eff} = \dot{V} \times l_{eff} = 4600\ \text{m}^3/\text{h} \times 0.59 = 2714\ \text{m}^3/\text{h}$$

$$\dot{Q}_{eff} = \dot{Q} \times q_{eff} = 32.4\ \text{kW} \times 0.70 = 22.7\ \text{kW}$$

$$t_{LA\ eff} = t_{LE} + \Delta t_{L\ eff} \quad \Delta t_{L\ eff} = \Delta t_{LO} \times e$$

$$\Delta t_{L\ eff} = (41 - 20) \times 1.20 = 25.2\ \text{K}$$

$$t_{LA\ eff} = 20 + 25.2 = 45.2\ ^\circ\text{C}$$

Item	Quantity	Art. no.	Individual price	Total price
	<p>Top Wing</p> <p>Air heater for the installation on ceiling for operation with circulating air or to a false ceiling for circulating air or mixed air operation.</p> <p>Panelling powder-coated, colour white RAL 9016, standard with spacers (100 mm).</p> <p>Base device with: Single-phase motor 230V / 50Hz as external rotor motor with crescent wing. alternative: Three-phase motor 3 x 400V / 50Hz with impeller.</p> <p>Heat exchanger Cu/Al with 3 pipe rows, two-lead system for heating or cooling.</p> <p>Air guidance lamellas individually adjustable.</p> <p>Technical data:</p> <p>Volume flow m³/h thermal output kW Air warming from to °C Heating medium / °C Water resistance kPa Motor speed min⁻¹ Motor output kW Operating voltage V Nominal current A Degree of protection</p> <p>Dimensions: Length: mm Width: mm Height: mm Weight: kg</p> <p>Manufactured by: Wolf</p> <p>Device type: TLHD</p>			

Item	Quantity	Art. no.	Individual price	Total price
Accessories				
Shut-off set for supply and return; passage design.				
Shut-off set for supply and return; corner design.				
Siphon as water trap and condensate drain, for TLHD with cooling				
Top filter for TLHD, grade G1, with attachment clips, not suitable for duct connection.				
Suction ring for TLHD not suitable for duct connection.				
Empty element, panelling double-walled 25 mm, insulated.				
Metal adapter sheet, insulated.				
Shifter piece for compensation of different dimensions				
Flexible canvas connector, for connection to TLHD				
Flexible canvas connector, for connection to duct				
Flexible canvas connector, for connection to roof lead-through				
Filter attachment box, with filter grade G4				
Attachment frame for the connection of shutter and circulating air suction grid				
Circulating air suction grid, colour white RAL 9016				
Shutter, for duct				
Shutter, for roof lead-through				
Wall connection element, for duct				
Installation frame, for weather guard grids				
Weather guard grid				
Suction hood wall				
Suction hood top				
Rain hood top				
Roof lead-through				
Covering collar, for roof lead-through				
Ceiling exhaust TD, without heat exchanger, without fan motor unit, as ceiling exhaust				
Fan element, KG 15/20, as auxiliary fan				
Hanging bracket for mounting of supply air device and empty element				
Differential pressure switch for filter monitoring				
Universal panelling metal sheet, front side				
Universal panelling metal sheet, square				

Item	Quantity	Art. no.	Individual price	Total price
Electrical accessories:				
RKE	Room temperature-dependent, continuous speed control with room sensor (230 V / 50/60 Hertz / 6 A) Suitable for heating and air conditioning w x h x d: 185 x 231 x 113			
RKD	Room temperature-dependent, continuous speed control with room sensor (3 x 400 V / 50/60 Hertz / 8 A) Suitable for heating and air conditioning w x h x d: 255 x 190 x 140			
	Analogue timer for set-back operation with weekly program for control RKE and RKD			
	One-position switch D1 Full motor protection switch for single-speed fan operation Performance max. 3 kW, operating voltage 400 V, control voltage 230 V, degree of protection IP 54; dimensions w x h x d: 105 x 170 x 135 mm.			
	Two-position switch DS Full motor protection switch for two-speed fan operation Performance max. 4 kW, operating voltage 400 V, control voltage 230 V, degree of protection IP 54; dimensions w x h x d: 105 x 170 x 135 mm.			
	Five-position switch D5-1 Full motor protection switch for 5-speed fan operation Current max. 1A, operating voltage 400 V, control voltage 230 V, degree of protection IP 40; dimensions w x h x d: 150 x 200 x 175 mm.			
	Five-position switch D5-3 Full motor protection switch for 5-speed fan operation Current max. 2A, operating voltage 400 V, control voltage 230 V, degree of protection IP 20; dimensions w x h x d: 230 V x 310 x 185 mm.			
	Five-position switch D5-7 Full motor protection switch for 5-speed fan operation Current max. 4A, operating voltage 400 V, control voltage 230 V, degree of protection IP 20; dimensions w x h x d: 230 V x 310 x 185 mm.			
	Five-position switch D5-12 Full motor protection switch for 5-speed fan operation Current max. 7A, operating voltage 400 V, control voltage 230 V, degree of protection IP 20; dimensions w x h x d: 230 V x 310 x 185 mm.			
	Control unit A2 for automatic two-speed fan operation only in connection with a 2-position room thermostat art. no. 273 4600 or a 2-position room thermostat clock art. no. 273 5400; dimensions w x h x d: 170 x 220 x 110 mm.			
	Five-position switch E5-3 Full motor protection switch for 5-speed fan operation with single-phase motor Current max. 3 A, operating voltage 230 V Degree of protection IP 40; dimensions w x h x d: 150 x 200 x 175 mm.			
	Five-position switch E5-7T Full motor protection switch for 5-speed fan operation with single-phase motor Current max. 7 A, operating voltage 230 V Degree of protection IP 40; dimensions w x h x d: 150 x 200 x 175 mm.			
	Intermediate terminal box for parallel operation of up to 3 devices			

Tendering Text TopWing Air heater TLHD

Item	Quantity	Art. no.	Individual price	Total price
Electrical accessories				
<p>Room thermostat for surface-mounted installation, with thermal feedback. Switching capacity 10 (4) A with 230 V, temperature range 5-30 °C, degree of protection IP 30; dimensions w x h x d: 71 x 71 x 30 mm.</p>				
<p>Room thermostat with circuit 2 positions for surface-mounted installation, with thermal feedback, in connection with the controller A2 suitable for automatic 2-position operation of the fan. Switching capacity 10 (4) A with 230 V, temperature range 5-30°C, degree of protection IP 30; dimensions w x h x d: 117 x 71 x 30 mm. Switching difference with stage I = 1.0 K with stage II = 1.5 K</p>				
<p>Room thermostat with summer-winter switch for switching heating-ventilation; for surface-mounted installation, with thermal feedback. Switching capacity 6 (3) A with 230 V, temperature range 5-30°C, degree of protection IP 30; dimensions w x h x d: 117 x 71 x 30 mm.</p>				
<p>Room thermostat clock with daily/weekly program for socket mounting, daily or weekly program (adjustable) for separately adjustable day or night temperature. Switching capacity 5 A with 230 V, temperature range 6-26°C, degree of protection IP 30; dimensions w x h x d: 162 x 80 x 44 mm.</p>				
<p>Room thermostat clock with circuit, 2-position with daily/weekly program Daily or weekly program (adjustable) for separately adjustable day or night temperature; in connection with the controller A2 suitable for the automatic 2-position operation of the fan. Switching capacity 6 A with 230 V, temperature range 6-26°C, degree of protection IP 30; dimensions w x h x d: 162 x 80 x 44 mm.</p>				
<p>Room thermostat clock with daily/weekly program and temperature sensor separate daily or weekly program (adjustable) for separately adjustable day and/or night temperature; temperature sensor with 2 m cable and wall holder for sensor. Switching capacity 10 A at 230 V, temperature range 6-34 °C, degree of protection IP 30. Dimensions w x h x d: 162 x 80 x 44 mm.</p>				
<p>Room thermostat in industrial design Switching capacity 10 (3) A at 230 V, temperature range 0-35 °C, degree of protection IP 54. Dimensions w x h x d: 87 x 123 x 83 mm.</p>				
<p>Servomotor for shutter, continuous, 230 V.</p>				
<p>Servomotor for shutter open/closed, 230 V.</p>				
<p>Automatic relay A1 for servomotor open/closed.</p>				
<p>Automatic relay A1S with position indicator for servomotor continuous.</p>				
<p>Position indicator for switching cabinet front mounting for the operation of the servomotor, continuous, in connection with the automatic relay A1.</p>				
<p>Position indicator for surface-mounted installation for the operation of the servomotor, continuous, in connection with the automatic relay A1.</p>				
<p>Differential pressure switch for monitoring of the filter.</p>				
<p>Frost protection contact thermostat: Setting range 20°C to 90°C for installation in return</p>				
<p>Frost protection thermostat SP-1 incl. immersion sleeve: Setting range 10°C to 60°C for installation in return</p>				